

Kennedy
Wire Rope & Sling Company

SYNTHETIC SLING
C A T A L O G



45+
YEARS OF EXCELLENCE

For more information, visit us at kwrs.com 



KENNEDY WIRE ROPE & SLING COMPANY

For over 45 years, Kennedy Wire Rope & Sling Company has been dedicated to providing the highest quality lifting and rigging equipment to the many industries we serve. We strive to be an industry leader and remain dedicated to providing our valued customers with the very best the industry has to offer. All of our slings are fabricated in ISO 9001:2015 certified facilities, and all hardware we supply is manufactured to industry standards and meets all safety requirements. When you partner with us, you can rest assured that our knowledgeable staff and superior products will help you get the job done safely. Contact us today!



Corpus Christi

302 Flato Rd.
Corpus Christi, TX 78405
(800) 289-1445 • (361) 289-1444



San Antonio

4202 Dividend Dr.
San Antonio, TX 78219
(833) 460-3095 • (210) 527-0555



Houston

5600 Surrey Square St.
Houston, TX 77017
(800) 392-5510 • (713) 673-7881

TABLE OF CONTENTS



Web Slings	3-20
Type 1 Triangle - Triangle	4
Type 2 Triangle - Choker	4
Type 3 Eye & Eye - Flat	5
Type 4 Eye & Eye - Twist	5
Type 5 Endless	6
Type 6 Reversed Eye	7
Type 7 Flat Eye	7
Type 8 Wide Body Basket	8
Type 9 Load Balancer Basket	8
Type 12 Two Leg Spreader	9
Type 13 Three Leg Spreader	10
Type 14 Four Leg Spreader	11
Inspection and Removal Criteria	12-14
Protecting Slings from Damage	15-16
Hitching Methods	17-20
Round Slings	21-38
Endless	22
Two Leg Spreader	23
Three Leg Spreader	24
Four Leg Spreader	25
Inspection and Removal Criteria	26-28
Protecting Slings from Damage	29-31
Hitching Methods	32-33
Connection Hardware	34-36
Super Powerlift Round Slings	37-38
HMPE Slings	39-50
Eye & Eye	40-41
Endless	42-43
HMPE Fiber vs. Steel	44
Physical Properties of HMPE	45-46
Sling Configuration	47-48
Removal Criteria	49
Sling Protection	50



WEB SLINGS

Synthetic web slings are essential lifting tools widely used across industries for their strength, flexibility, and lightweight design. Constructed from high-quality synthetic materials such as nylon or polyester, these slings provide a cost-effective and reliable solution for handling loads of various sizes, shapes, and weights.

Key advantages of synthetic web slings include:

- **Lightweight and Easy to Handle:** Flexible design allows for quick setup and adjustment, helping reduce operator fatigue.
- **Surface Protection:** The wide sling body provides excellent load stability while minimizing the risk of surface damage to delicate or finished items.
- **Versatility:** Synthetic web slings can be used in vertical, choker, or basket hitch configurations to accommodate diverse lifting requirements.

Ideal for industries such as construction, manufacturing, transportation, and warehousing, synthetic web slings deliver a balance of safety, efficiency, and reliability. Regular inspection and proper usage are essential to ensure optimal performance and safety compliance.

Don't see what you need? Our team specializes in bringing your project requirements to life. Give our sales team a call to discuss the possibilities!



**TYPE 1 TRIANGLE
TRIANGLE & CHOKER**

Nylon or polyester web slings, for use in vertical, choker, and basket hitch applications.

**TYPE 2 TRIANGLE
TRIANGLE & TRIANGLE**



Stock # *	Width (")	Ply	Vertical	Choker	Basket	60°	45°	30°
-1-92	2	1	3,100	2,450	6,200	5,350	4,350	3,100
-2-92	2	2	6,200	4,950	12,400	10,700	8,750	6,200
-1-93	3	1	4,700	3,750	9,400	8,100	6,600	4,700
-2-93	3	2	8,800	7,000	17,600	15,200	12,400	8,800
-1-94	4	1	6,200	4,950	12,400	10,700	8,750	6,200
-2-94	4	2	11,000	8,800	22,000	19,050	15,550	11,000
-1-96	6	1	9,300	7,400	18,600	16,100	13,150	9,300
-2-96	6	2	16,500	13,200	33,000	28,550	23,300	16,500
-2-98	8	2	22,400	17,900	44,800	38,750	31,650	22,400
-2-910	10	2	28,000	22,400	56,000	48,450	39,600	28,000
-2-912	12	2	32,000	27,250	64,000	55,400	45,250	32,000

Rated capacities are in pounds. Choker rated capacities apply to Type 2 slings only. Type 1 slings are not to be used in a choker hitch.

Aluminum fittings are used on 1-ply slings (2", 4", and 6" wide webbing only) and steel on 2-ply slings. Steel may be specified on 1-ply slings.

*Stock # prefixes:

- TCA - Type 1 - aluminum fittings
- TCS - Type 1 - steel fittings
- TTA - Type 2 - aluminum fittings
- TTS - Type 2 - steel fittings

WARNING

See page 12-14 for inspection and removal criteria

WARNING:

Never use aluminum fittings where fumes, vapors, mists or liquids of caustics are present. Aluminum fittings are degraded by salt water and should not be cleaned with chlorine based solutions.

TYPE 3 & 4

FLAT EYE & TWIST EYE

Nylon or polyester web slings, for use in vertical, choker, and basket hitch applications.

WARNING See page 12-14 for inspection and removal criteria

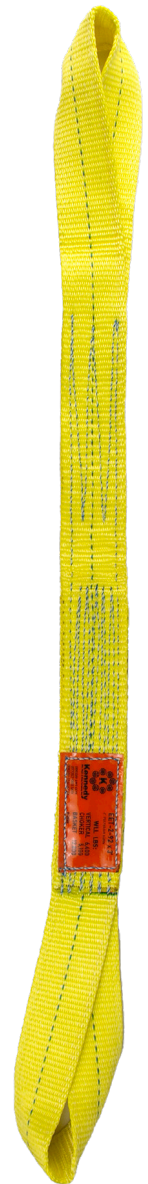

Stock # *	Width (")	Ply	Vert	Choker Hitch	Basket Hitch			Eye Length (")	Eye Width (")	
					Degrees					
					60°	45°	30°			
-1-91	1	1	1,600	1,250	3,200	2,750	2,250	1,600	9	1
-2-91	1	2	3,100	2,450	6,200	5,350	4,350	3,100	9	1
-3-91	1	3	4,100	3,300	8,200	7,050	5,750	4,100	12	1
-4-91	1	4	5,500	4,400	11,000	9,500	7,750	5,500	12	1
-1-92	2	1	3,100	2,450	6,200	5,350	4,350	3,100	12	2
-2-92	2	2	6,200	4,950	12,400	10,700	8,750	6,200	12	2
-3-92	2	3	8,200	6,600	16,400	14,100	11,550	8,200	12	2
-4-92	2	4	11,000	8,800	22,000	19,050	15,550	11,000	12	2
-1-93	3	1	4,700	3,750	9,400	8,100	6,600	4,700	12	1-1/2
-2-93	3	2	8,800	7,000	17,600	15,200	12,400	8,800	12	1-1/2
-3-93	3	3	12,300	9,900	24,600	21,150	17,300	12,300	18	1-1/2
-4-93	3	4	16,400	13,100	32,800	28,400	23,150	16,400	18	1-1/2
-1-94	4	1	6,200	4,950	12,400	10,700	8,750	6,200	14	2
-2-94	4	2	11,000	8,800	22,000	19,050	15,550	11,000	14	2
-3-94	4	3	15,300	12,200	30,600	26,300	21,550	15,300	18	2
-4-94	4	4	20,400	16,300	40,800	35,300	28,850	20,400	18	2
-1-96	6	1	9,300	7,400	18,600	16,100	13,150	9,300	24	2
-2-96	6	2	16,500	13,200	33,000	28,550	23,300	16,500	24	2
-3-96	6	3	22,900	18,300	45,800	39,300	32,250	22,900	24	3
-4-96	6	4	30,600	24,450	61,200	53,000	43,250	30,600	24	3
-1-98	8	1	11,800	9,400	23,600	20,400	16,650	11,800	24	3
-2-98	8	2	22,700	18,150	45,400	39,300	32,100	22,700	24	3
-3-98	8	3	30,700	24,600	61,400	52,800	43,250	30,700	24	4
-4-98	8	4	40,900	32,750	81,800	70,450	57,750	40,900	24	4
-1-910	10	1	14,700	11,750	29,400	25,450	20,750	14,700	24	4
-2-910	10	2	28,400	22,700	56,800	49,150	40,150	28,400	24	4
-3-910	10	3	36,000	28,800	72,000	61,900	50,750	36,000	30	5
-4-910	10	4	48,000	38,400	96,000	82,550	67,650	48,000	30	5
-1-912	12	1	17,600	14,050	35,200	30,450	24,850	17,600	30	5
-2-912	12	2	34,100	27,250	68,200	59,050	48,200	34,100	30	5
-3-912	12	3	40,300	32,200	80,600	69,300	56,800	40,300	36	6
-4-912	12	4	53,700	43,000	107,400	92,450	75,800	53,700	36	6

*Use prefix "EET" for Twist Eye and "EEF" for Flat Eye stock numbers. Rated capacities are in pounds. Consider using round slings in applications requiring 3- and 4-ply slings wider than 6".

SYNTHETIC SLINGS WEB SLINGS



TYPE 5 ENDLESS

Nylon or polyester endless web slings, for use in vertical, choker, and basket hitch applications.

! WARNING ! See page 12-14 for inspection and removal criteria

Stock #	Width (")	Ply	Vertical	Choker Hitch		Basket Hitch		
						Degrees		
						60°	45°	30°
EN-1-91	1	1	3,200	2,550	6,400	5,500	4,500	3,200
EN-2-91	1	2	6,200	4,950	12,400	10,700	8,750	6,200
EN-3-91	1	3	8,200	6,600	16,400	14,100	11,550	8,200
EN-4-91	1	4	11,000	8,800	22,000	19,050	15,550	11,000
EN-1-92	2	1	6,200	4,950	12,400	10,700	8,750	6,200
EN-2-92	2	2	12,400	9,900	24,800	21,450	17,500	12,400
EN-3-92	2	3	16,500	13,200	33,000	28,350	23,250	16,500
EN-4-92	2	4	22,000	17,600	44,000	38,100	31,100	22,000
EN-1-93	3	1	9,400	7,500	18,800	16,250	13,250	9,400
EN-2-93	3	2	17,600	14,050	35,200	30,450	24,850	17,600
EN-3-93	3	3	24,700	19,800	49,400	42,450	34,800	24,700
EN-4-93	3	4	32,900	26,300	65,800	56,950	46,500	32,900
EN-1-94	4	1	12,400	9,900	24,800	21,450	17,500	12,400
EN-2-94	4	2	22,000	17,600	44,000	38,100	31,100	22,000
EN-3-94	4	3	30,600	24,500	61,200	52,600	43,100	30,600
EN-4-94	4	4	40,800	32,600	81,600	70,650	57,700	40,800
EN-1-96	6	1	18,600	14,850	37,200	32,200	26,300	18,600
EN-2-96	6	2	33,000	26,400	66,000	57,150	46,650	33,000
EN-3-96	6	3	45,900	36,700	91,800	78,900	64,700	45,900
EN-4-96	6	4	61,200	48,950	122,400	106,000	86,550	61,200
EN-1-98	8	1	21,200	16,950	42,400	36,700	29,950	21,200
EN-2-98	8	2	42,300	33,800	84,600	73,250	59,800	42,300
EN-3-98	8	3	61,400	49,100	122,800	105,600	86,550	61,400
EN-4-98	8	4	81,900	65,500	163,800	140,900	115,500	81,900
EN-1-910	10	1	26,500	21,200	53,000	45,850	37,450	26,500
EN-2-910	10	2	52,900	42,300	105,800	91,600	74,800	52,900
EN-3-910	10	3	72,000	57,600	144,000	124,650	101,800	72,000
EN-4-910	10	4	96,000	76,800	192,000	165,100	135,350	96,000
EN-1-912	12	1	31,800	25,400	63,600	55,050	44,950	31,800
EN-2-912	12	2	63,500	50,800	127,000	109,950	89,800	63,500
EN-3-912	12	3	80,000	64,000	160,000	138,550	113,100	80,000
EN-4-912	12	4	107,000	86,000	214,000	184,900	151,300	107,000

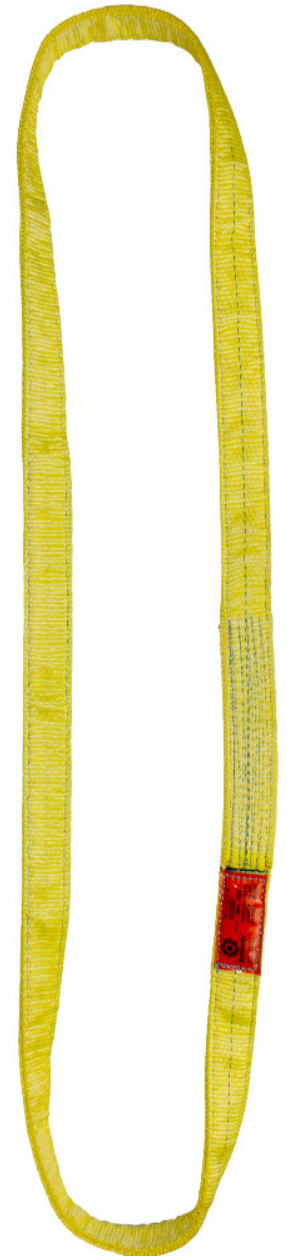

Rated capacities are in pounds. Consider using round slings in applications requiring 3- and 4-ply slings wider than 4". End tapering available in 1- and 2-ply slings 2" - 12"

TYPE 6 REVERSED EYE

An exceptionally durable sling that features full body and eye protection. The eye openings are 90 degrees to the sling body for tighter choker hitches and easy vertical and basket hitch rigging.

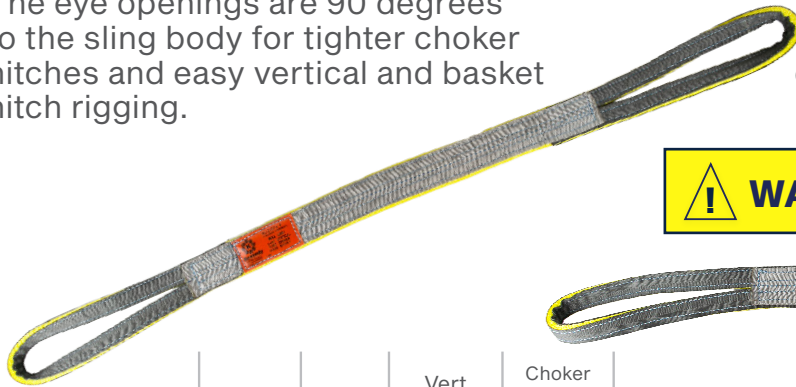



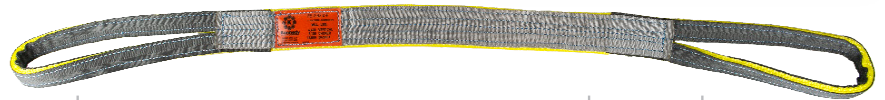

TYPE 7 FLAT EYE

Flat eye slings have the same construction as Type 6, but with eyes in line with the sling body. These slings allow rigging through tight spaces and easy removal from under loads. Ideal for choker and basket hitches.

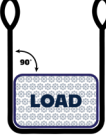

! WARNING ! See page 12-14 for inspection and removal criteria

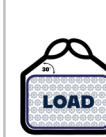
Stock #*	Width (")	Ply	Vert 	Choker Hitch 	Basket Hitch				Eye Width (")	Eye Length (")
					Degrees					
					 90° LOAD	 60° LOAD	 45° LOAD	 30° LOAD		
-1-92	2	1	3,200	2,550	6,400	5,500	4,500	3,200	1	9
-2-92	2	2	6,200	4,950	12,400	10,700	8,750	6,200	1	12
-3-92	2	3	8,200	6,600	16,400	14,100	11,550	8,200	1	12
-4-92	2	4	11,000	8,800	22,000	19,050	15,550	11,000	1	12
-1-93	3	1	4,600	3,650	9,200	7,950	6,500	4,600	1-1/2	12
-2-93	3	2	9,400	7,500	18,800	16,250	13,250	9,400	1-1/2	12
-3-93	3	3	12,300	9,800	24,600	21,300	17,350	12,300	1-3/4	12
-4-93	3	4	16,500	13,200	33,000	28,550	23,300	16,500	1-3/4	12
-1-94	4	1	6,200	4,950	12,400	10,700	8,750	6,200	1	12
-2-94	4	2	12,400	9,900	24,800	21,450	17,500	12,400	2	12
-3-94	4	3	16,500	13,200	33,000	28,350	23,250	16,500	2	18
-4-94	4	4	22,000	17,600	44,000	38,100	31,100	22,000	2	18
-1-96	6	1	9,400	7,500	18,800	16,250	13,250	9,400	1 1/2	12
-2-96	6	2	17,600	14,050	35,200	30,450	24,850	17,600	1 1/2	18
-3-96	6	3	24,700	19,800	49,400	42,450	34,800	24,700	3	24
-4-96	6	4	32,900	26,300	65,800	56,950	46,500	32,900	3	28

Rated capacities are in pounds. *Use prefix "FE" for Flat Eye and "RE" for Reversed Eye stock numbers



**TYPE 8
WIDE BODY
BASKET**

Designed for basket hitches requiring increased surface area for load stability and proper handling of fragile or highly finished surfaces. Sling eyes can be tapered to fit hoist or crane hooks and are reinforced for added durability.



Stock #	Width (")	Ply	Basket Hitch	Eye Length (")	Eye Width (")
					
WBB-1-96	6	1	19,000	12	1-1/2
WBB-2-96	6	2	35,000	15	1-1/2
WBB-1-98	8	1	25,000	12	2
WBB-2-98	8	2	46,000	15	2
WBB-1-912	12	1	37,000	15	2
WBB-2-912	12	2	68,000	18	3
WBB-1-916	16	1	50,000	18	3
WBB-2-916	16	2	85,000	24	4
WBB-1-920	20	1	57,000	24	3-1/2
WBB-2-920	20	2	96,000	24	5
WBB-1-924	24	1	60,000	24	4
WBB-2-924	24	2	107,000	24	4

Rated capacities are in pounds.

**TYPE 9
LOAD BALANCER
BASKET**

Designed for basket hitches requiring increased surface area for load stability and proper handling of fragile or highly finished surfaces. These slings have a lower rated capacity than the Wide Body Basket. Sling eyes are constructed to fit properly on small hoist hooks.



! WARNING ! See page 12-14 for inspection and removal criteria

Stock #	Width (")	Ply	Basket Hitch	Eye Width (")	Eye Length (")
					
LBB-1-96	6	1	6,000	1	9
LBB-1-98	8	1	6,000	1	12
LBB-1-910	10	1	6,000	1	15
LBB-1-912	12	1	6,000	1	18

Rated capacities are in pounds.

TYPE 12 TWO LEG SPREADER

WARNING

See page 12-14 for inspection and removal criteria

Nylon or polyester two leg spreaders are useful when the load is equipped with permanent lifting attachments. For such applications, two leg spreaders are lightweight, easy to use, and economical.

Stock #	Width (")	Ply	Degrees			Master Link Size (")	Hook Size (WLL)
			60° 	45° 	30° 		
OL-2-EEFC-1-91	1	1	2,750	2,250	1,600	3/4	1.5t Web Sling Hook
OL-2-EEFC-2-91	1	2	5,350	4,350	3,100	3/4	1.5t Web Sling Hook
OL-2-EEFC-1-92	2	1	5,350	4,350	3,100	3/4	1.5t Web Sling Hook
OL-2-EEFC-2-92	2	2	10,700	8,750	6,200	1	3t Web Sling Hook
OL-2-EEFC-1-93	3	1	8,100	6,600	4,700	1	3t Web Sling Hook
OL-2-EEFC-2-93	3	2	15,200	12,400	8,800	1	5t Web Sling Hook
OL-2-EEFC-4-93	3	4	28,400	23,150	16,400	1-1/4	*
OL-2-EEFC-1-94	4	1	10,700	8,750	6,200	1	3t Web Sling Hook
OL-2-EEFC-2-94	4	2	19,050	15,550	11,000	1	5t Web Sling Hook
OL-2-EEFC-4-94	4	4	35,300	28,850	20,400	1-1/2	*

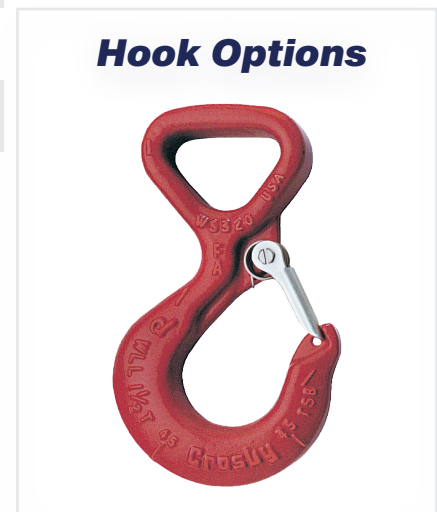
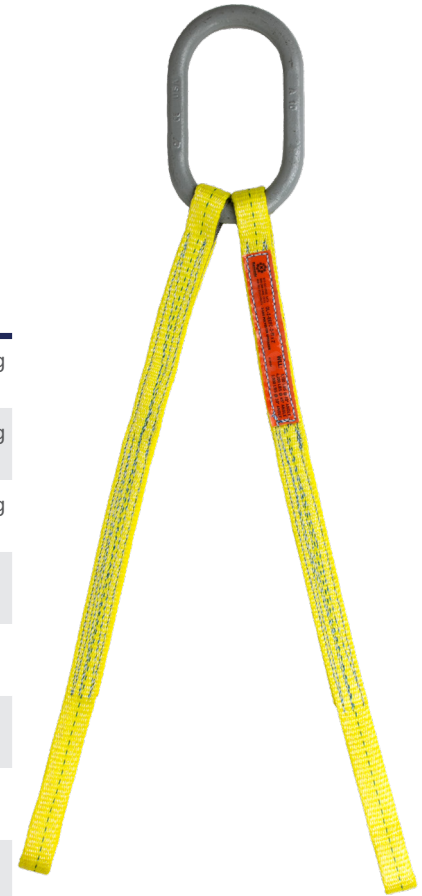

**Available when a connection fitting is used for attaching the hook to the eye. Please contact our sales team for additional information.*

Additional sizes available upon request. Please contact our sales team for special requirements.





**TYPE 13
THREE LEG SPREADER**

! WARNING ! See page 12-14 for inspection and removal criteria

Nylon or polyester three leg spreaders are useful when the load is equipped with permanent lifting attachments. For such applications, three leg spreaders are lightweight, easy to use, and economical.



Stock #	Width (")	Ply	Degrees			Master Link Size (")	Hook Size (WLL)
			60° 	45° 	30° 		
OL-3-EEFC-1-91	1	1	4,150	3,350	2,400	3/4	1.5t Web Sling Hook
OL-3-EEFC-2-91	1	2	8,050	6,550	4,650	1	1.5t Web Sling Hook
OL-3-EEFC-1-92	2	1	8,050	6,550	4,650	3/4	1.5t Web Sling Hook
OL-3-EEFC-2-92	2	2	16,100	13,150	9,300	1	3t Web Sling Hook
OL-3-EEFC-1-93	3	1	12,200	9,950	7,050	1-1/2	3t Web Sling Hook
OL-3-EEFC-2-93	3	2	22,850	18,650	11,400	1-1/2	5t Web Sling Hook
OL-3-EEFC-4-93	3	4	42,550	34,750	24,600	1-1/2	*
OL-3-EEFC-1-94	4	1	16,100	13,150	9,300	1-1/2	3t Web Sling Hook
OL-3-EEFC-2-94	4	2	28,550	23,300	16,500	1-1/2	5t Web Sling Hook
OL-3-EEFC-4-94	4	4	52,950	43,250	30,600	2	*

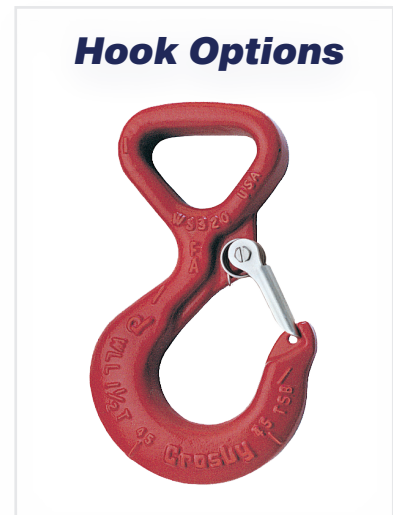

*Available when a connection fitting is used for attaching the hook to the eye. Please contact our sales team for additional information.

Additional sizes available upon request. Please contact our sales team for special requirements.



TYPE 14 FOUR LEG SPREADER



WARNING

See page 12-14 for inspection and removal criteria

Nylon or polyester four leg spreaders are useful when the load is equipped with permanent lifting attachments. For such applications, four leg spreaders are lightweight, easy to use, and economical.

Stock #	Width (")	Ply	Degrees			Master Link Size (")	Hook Size (WLL)
			60° 	45° 	30° 		
OL-4-EEFC-1-91	1	1	5,500	4,500	3,200	1-1/4	1.5t Web Sling Hook
OL-4-EEFC-2-91	1	2	10,700	8,750	6,200	1-1/4	1.5t Web Sling Hook
OL-4-EEFC-1-92	2	1	10,700	8,750	6,200	1-1/4	1.5t Web Sling Hook
OL-4-EEFC-2-92	2	2	21,450	17,500	12,400	1-1/4	3t Web Sling Hook
OL-4-EEFC-1-93	3	1	16,250	13,250	9,400	1-3/4	3t Web Sling Hook
OL-4-EEFC-2-93	3	2	30,450	24,850	17,600	1-3/4	5t Web Sling Hook
OL-4-EEFC-4-93	3	4	56,800	46,350	32,800	2	*
OL-4-EEFC-1-94	4	1	21,450	17,500	12,400	2	3t Web Sling Hook
OL-4-EEFC-2-94	4	2	38,050	31,100	22,000	2	5t Web Sling Hook
OL-4-EEFC-4-94	4	4	70,600	57,700	40,800	2-1/2	*



Hook Options



*Available when a connection fitting is used for attaching the hook to the eye. Please contact our sales team for additional information.

Additional sizes available upon request. Please contact our sales team for special requirements.



SLING INSPECTION

Slings must be regularly and properly inspected. Even seemingly “minor” damage to a web sling can significantly reduce its capacity to hold or lift objects and increases the chance that the sling will fail during use. If you are not sure whether a sling is damaged, **DO NOT USE IT.**

How to Inspect Slings

Inspect the entire sling visually and by touch, as some damage may be easier to feel than see. See page 14 for examples of common sling damage.

What to Do If You Identify Damage In a Sling

If you identify any of these types of damage in a sling, remove it from service immediately, even if the damage you feel or see is not as extensive as shown in the pictures on page 14. Slings that are removed from service must be destroyed and rendered completely unusable.

ASME B30.9-5.9 - Frequency of Inspection

A 3 stage procedure is recommended to help ensure that web slings are inspected with appropriate frequency.

- 1. Initial Inspection** - Slings must be inspected by a designated person as soon as they are received. This ensures that the correct web sling has been received, is undamaged, and meets the requirements for its intended use.
- 2. Frequent Inspection** - The entire sling must be inspected before each shift or day in normal service and before each use in severe service applications.
- 3. Periodic Inspection** - Every sling must be inspected “periodically” by a qualified and designated person. The frequency of periodic inspections is based on the sling’s actual or expected frequency of use, severity of service conditions, and the nature of the work performed with the sling.

REMOVAL CRITERIA

ASME B30.9-5.9 - Possible Defects

A sling shall be removed from service if any defects such as the following are visible:

- Missing or illegible sling identification tag
- Acid or caustic burns
- Melting or charring of any parts of the sling surface
- Snags, punctures, holes, tears, or cuts

- Broken or worn stitches
- Excessive abrasive wear
- Distortion of fittings
- Knots in any part of the sling
- Discoloration, brittle or stiff areas
- Other apparent defects which cause doubt as to the strength of the sling should be referred to the manufacturer for determination.

While most of the foregoing standards are quite specific regarding some removal criteria, a certain amount of judgment is involved in others. The issue of wear to the sling body, the selvage or webbing, and the sling eyes creates the greatest amount of contention.

Polyester vs Nylon

- Polyester and nylon webbing should not be exposed to temperatures exceeding 180°F due to softening (or actual melting) of the fibers.
- Consult the table to the right with regard to the effects of chemicals on synthetic web slings.
- Coatings are available for longer service life and wear resistance.
- Wear pads can be provided to minimize the effects of rough surfaces or angles which can abrade or cut the sling fabric.

Chemical	Nylon	Polyester
Acid	NO	*
Alcohol	OK	OK
Aldehydes	OK	NO
Strong Alkalis	OK	**
Bleaching Agents Dry	NO	OK
Cleaning Solvents	OK	OK
Ethers	OK	NO
Halogenated Hydrocarbons	OK	OK
Ketones	OK	OK
Oil, Crude	OK	OK
Oil, Lubricating	OK	OK
Water, Seawater	OK	OK
Weak Alkalis	OK	OK

** Disintegrated by concentrated sulfuric acid*

*** Degraded by strong alkalis at elevated temperatures*



INSPECTION CRITERIA



ACID OR CAUSTIC BURNS



CUT



CRUSHED WEBBING



EDGE CUT



MELTING OR CHARRING



ABRASIONS



PUNCTURE



SNAG



WELD SPATTER

⚠ WARNING ⚠

Failure to follow the care, use, and inspection instructions of a sling could result in severe personal injury or death.

Do NOT exceed rated capacities.

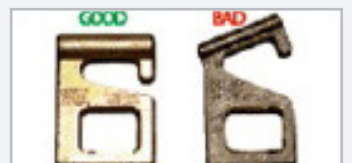

DAMAGED HARDWARE



EMBEDDED MATERIALS

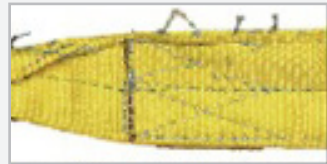

BROKEN OR WORN STITCHES



DAMAGED EYE



KNOT



UV DEGRADATION



TENSILE BREAK



MISSING OR ILLEGIBLE TAG

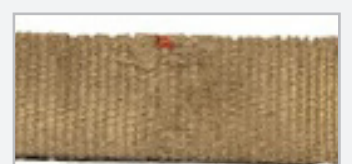

RED CORE YARN

PROTECTING SLINGS FROM DAMAGE

Environmental Considerations

Environmental factors such as sunlight, dirt, and temperature/humidity changes can accelerate web sling deterioration. The rate depends on exposure and sling thickness, with single-ply slings degrading faster than multi-ply slings. Web slings used outdoors regularly should be removed from service within 2 to 4 years and highly scrutinized during inspections. Visible signs of deterioration include the following:

- Fading of color
- Uneven or disoriented surface yarn of the webbing
- Shortening of sling length
- Reduction in elasticity and strength of the sling material due to exposure to sunlight, often evident by accelerated abrasive damage to the surface yarn of the sling
- Breakage or damage to yarn fibers, often evident by a fuzzy appearance of the web
- Stiffening of the web, which can become particularly evident when web slings are exposed to outdoor conditions without being used or cyclically tensioned

Mechanical Considerations

Avoid any action that may cause sling damage, such as:

- Dropping or dragging slings
- Pulling Slings from under loads while the load is resting on the sling
- Shortening or adjusting sling using methods not approved by the sling manufacturer
- Twisting, kinking or knotting the sling
- Exposing slings to acids, alkalis, heat damage or weld splatter
- Using slings in or allowing exposure to temperatures above 194°F (90°C) or below -40°F (-40°C)
- “Tip loading” a sling on a hook instead of centering it in the base or “bowl” of the hook
- Using hooks, shackles or other hardware that have sharp edges or surfaces
- Running/driving over slings with a vehicle or other equipment

Synthetic slings can degrade due to certain chemicals, with the extent influenced by time, temperature, and concentration. Water absorption can reduce the strength of **nylon** web slings by 10-15%, which is restored upon drying. For specific applications, consult the manufacturer.



continued

Sling Protection Considerations

Synthetic web slings can be damaged, abraded or cut as tension and compression between the sling, the connection points, and the load develops. Surfaces in contact with the sling do not have to be very abrasive or have “razor” sharp edges in order to create the conditions for sling failure. Web slings must ALWAYS be protected from being cut or damaged by corners, edges, protrusions or abrasive surfaces with materials of sufficient strength and construction to prevent sling damage.

There are many ways to protect slings from such damage. A qualified person may choose to use appropriately engineered protectors/softeners—commercially available products (e.g., sleeves, wear pads, edge wraps, body wraps, corner protectors, etc.) specifically designed to protect slings from damage. This person might also design and construct methods of protection so long as the sling is adequately protected from and/or kept off of the damaging edge surface.

No matter the method, the goal is to ensure that the sling maintains its ability to securely handle the load while avoiding contact with damaging or abrasive surfaces under tension. A qualified person must carefully consider the most appropriate means to accomplish this goal.

In any case, a qualified person must ensure that the protection method chosen is appropriate for the types of damage to which the slings will be exposed. For instance, some protection provides abrasion resistance, but offers virtually no protection against cuts.

Several “test” lifts, done in a non-consequence setting may be needed to determine the suitability of the protection device(s). After each “test” lift, the protection device(s) and the sling(s) need to be inspected for damage and suitability. You should keep in mind that no protection is “cut proof,” and you should always operate within the specified limits of the sling and its accessories (e.g., fixtures, hardware, protection, etc.).

Sling Storage and Maintenance

- Slings should be stored in a cool, dry, and dark location, away from dirt, abrasives, or contaminants serves to maintain the optimum lifting capacity.
- Cleaning slings to remove dirt, grime, and abrasives (such as sand or caliche) will help to prolong service life. These contaminants wear the fibers and reduce their strength.
- Slings should be cleaned with a mild soap. Do not pressure wash or steam clean. Capacity tags must be legible. After rinsing the sling, it should be hung to air dry.

Length Tolerances For New Web Slings

Sling Type	Length Tolerance*
1-Ply	$\pm (1.5'' + 1.5\% \text{ of sling length})$
2-Ply	$\pm (2.0'' + 2\% \text{ of sling length})$
3-Ply & 4-Ply	$\pm (3.0'' + 3\% \text{ of sling length})$

*For matching length slings, please contact a salesperson.

COMMON TYPES OF SLING HITCHES

Vertical Pull:

A method of rigging in which the load is attached to one end of the synthetic web sling, usually being attached by means of a hook or shackle, and the other end of the sling is attached to the lifting device. A tag line should be used to prevent load rotation.

WARNING:

Any single sling hitch must never be used to transport a load that is not balanced.

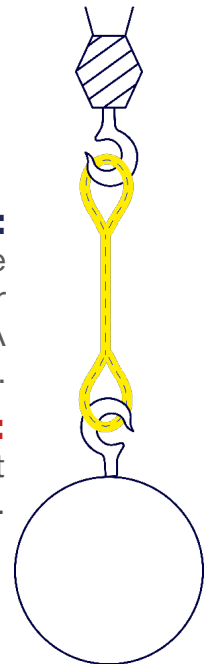

Basket Hitch:

A method of rigging in which the synthetic web sling is passed around the load and both ends are attached overhead.

WARNING:

Rated capacities are affected by the sling to load angle when used in multi-leg bridles or basket hitches. Sling angles of less than 30 degrees are not recommended.

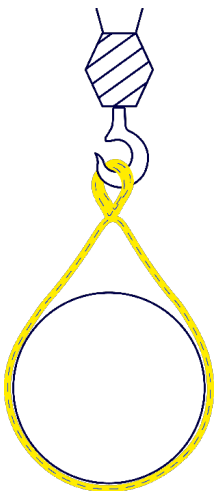

Double Wrapped Choker Hitch:

A method of rigging in which the web sling is passed around the load twice and then through itself, normally through the sling eye, and then attached to the lifting device.

WARNING:

Any single sling hitch must never be used to transport a load that is not balanced.

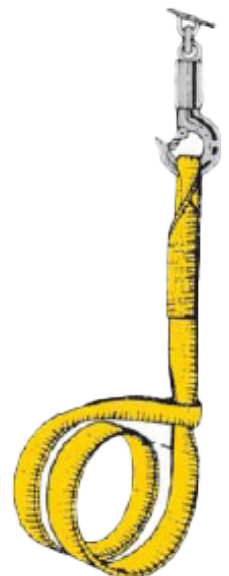



continued

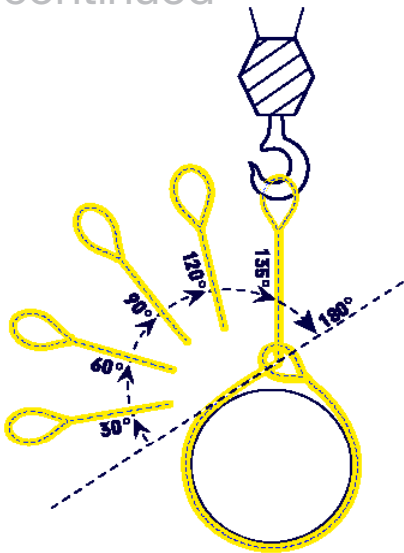

Choker Hitch:

A method of rigging in which the web sling is passed around the load and then through itself, normally through the sling eye, and then attached to the lifting device. Slings used in a choker hitch must be of sufficient length to ensure that the choke point is always on the sling body – not on the sling eye, fitting, base of the eye or fitting, splice or tag. The chart shows the capacity reduction of a sling used in a choker hitch.

Angle of Choke Degree	Rated Capacity
Over 120	100%
90-120	87%
60-89	74%
30-59	62%
0-29	49%

PROPER HITCHING METHODS FOR WEB SLINGS

Single Leg Hitch:

Single leg hitches such as the single leg vertical and the single choker hitch may not provide optimum control over the load. In these hitches only one synthetic web sling supports the load. In a single choker hitch, there is always a part of the synthetic web sling at the choke point not in contact with the bundle being lifted.

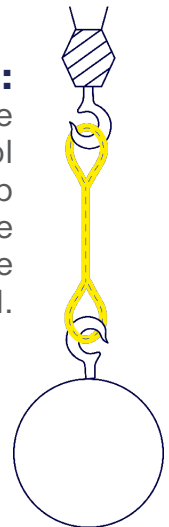

Double Wrap Choker Hitch:

The double wrap choker hitch or the double wrap hitch provides full 360 degree contact with the load.

WARNING: When using a double-wrap hitch, avoid overlapping slings, as it can lead to uneven load distribution, sling damage, and compromised safety.

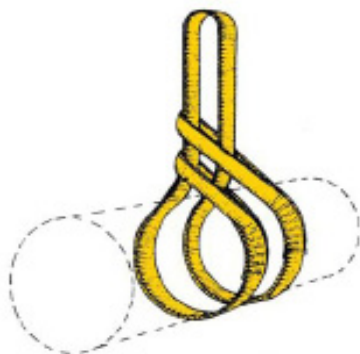
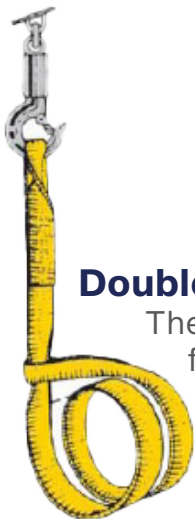

Correct



Incorrect

Double Choker Hitch:

The double choker hitch appears to be preferred by many riggers because it is twice as strong as a single choker hitch in the same sling type. When this hitch is made in the right way, both legs will automatically equalize over the crane hook. However, when it is made wrong, there is usually no equalization and one of the legs will support most of the load.

Basket Hitch:

Basket hitches, whether single or double, may be used successfully in a variety of applications, however, they have inherent limitations.

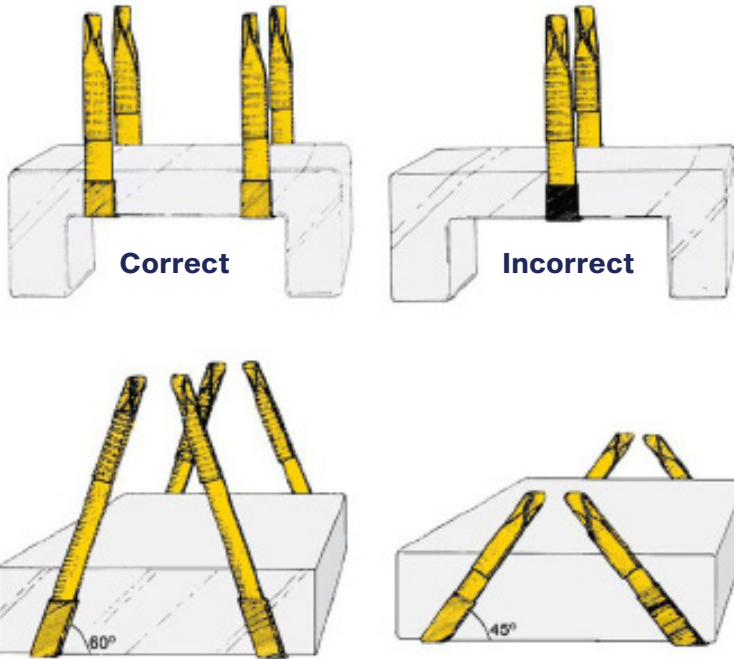

WARNING: As sling angles decrease, the risk of slings skipping across the load or the load slipping out of the slings becomes greater, creating an unbalanced condition.

Degrees from Horizontal	Tension Factor
90	1.000
85	1.004
80	1.015
75	1.035
70	1.064
65	1.104
60	1.155
55	1.221
50	1.305
45	1.414
40	1.555
35	1.742
30	2.000

Increased Tension on Slings Used at Angles

Another important consideration is the sling-to-load angle which is the angle formed between a horizontal line and the sling leg or body. This angle is very important and can have a dramatic effect on the rated capacity of the sling. When the sling-to-load angle decreases, the load on each leg increases. Sling angles less than 30 degrees are not recommended.

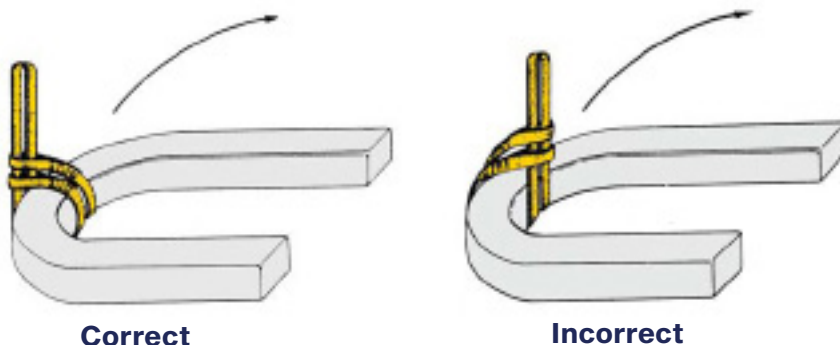

Turning Hitch:

When turning a load, always use a choker hitch. If the turning hitch is made the wrong way, the turning action of the load will loosen the hitch, causing it to slip.

Note: A basket hitch should not be used for turning a load

continued

Two Ends Down-Single Basket Hitch:

The following hitches can all be classified as “hook equalizing hitches”. Since the bite of the sling is on the hook, the sling is free to slip through the hook according to the distribution of weight on the various legs. There are dangers to be avoided in the use of these hitches.

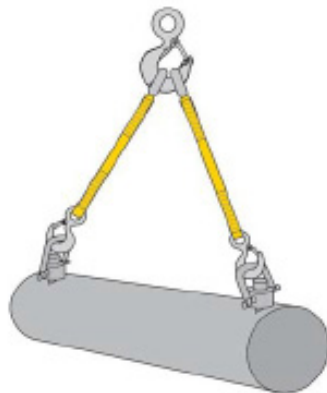

Correct

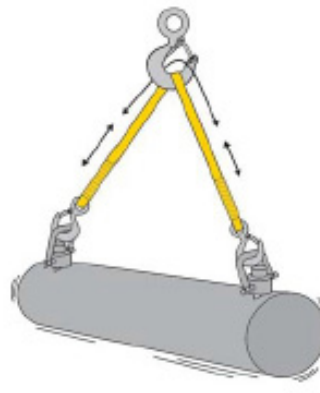

Incorrect

Four Ends Down-Double Basket Hitch:

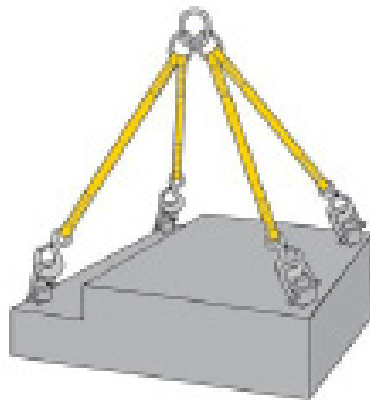

Correct

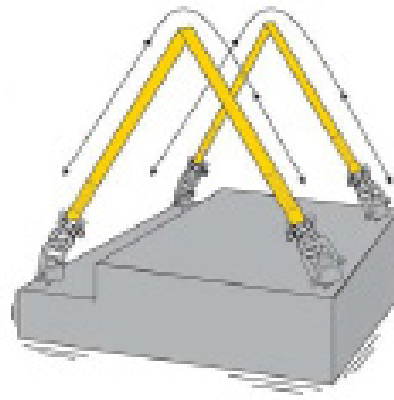

Incorrect

Four Ends Down-Double Basket Hitch:



Correct



Incorrect



ROUND SLINGS

Polyester round slings are versatile and durable lifting solutions designed to handle loads safely and efficiently in a variety of applications. Made from high-strength polyester fibers encased in a seamless tubular sleeve, these slings offer exceptional performance, especially when lifting delicate or irregularly shaped loads.

Key advantages of polyester round slings include:

- **Flexibility and Lightweight Design:** Easily adjustable to different load shapes, they reduce strain on riggers during setup and handling.
- **Load Protection:** The soft polyester material minimizes damage to the surface of the load, making them ideal for sensitive or finished items.
- **Versatile Applications:** Suitable for vertical, choker, and basket hitch configurations, these slings adapt to diverse lifting requirements.
- **Long Service Life:** The endless design allows rotation to distribute wear evenly, extending the sling's lifespan.

Commonly used in industries such as construction, shipping, manufacturing, and warehousing, polyester round slings provide a balance of strength, safety, and versatility. Proper inspection and adherence to rated capacities ensure safe and effective lifting operations.



POWER LIFT ROUND SLING ENDLESS

Polyester endless round slings are durable, versatile lifting tools made from high-strength polyester fibers with a protective tubular cover.

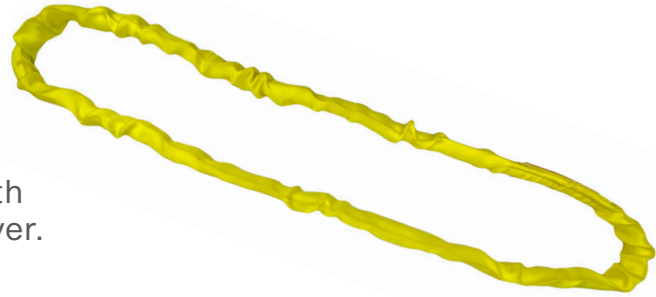

Stock #	Color Code	Vert	Choker	Basket Hitches				Weight/ Ft.	Vertical & Choker Only	
				90°	60°	45°	30°		Sling Width @ Load (")	Minimum Hardware Diameter (")
PL1	PURPLE	2,600	2,100	5,200	4,500	3,700	2,600	0.30	1.00	0.44
PL2	GREEN	5,300	4,200	10,600	9,200	7,500	5,300	0.40	1.38	0.63
PL3	YELLOW	8,400	6,700	16,800	14,500	11,900	8,400	0.50	1.75	0.75
PL4	TAN	10,600	8,500	21,200	18,400	15,000	10,600	0.60	1.88	0.88
PL5	RED	13,200	10,600	26,400	22,900	18,700	13,200	0.80	2.00	1.00
PL6	WHITE	16,800	13,400	33,600	29,100	23,800	16,800	0.90	2.13	1.13
PL7	BLUE	21,200	17,000	42,000	36,700	30,000	21,200	1.20	2.63	1.25
PL8	ORANGE	25,000	20,000	50,000	43,300	35,400	25,000	1.50	2.88	1.50
PL9	ORANGE	31,000	24,800	62,000	53,700	43,800	31,000	2.00	3.25	1.62
PL10	ORANGE	40,000	32,000	80,000	69,300	56,600	40,000	2.80	3.63	2.00
PL11	ORANGE	53,000	42,400	106,000	91,800	75,000	53,000	3.60	4.00	2.13
PL12	ORANGE	66,000	52,800	132,000	114,300	93,400	66,000	4.60	4.63	2.25
PL13	ORANGE	90,000	72,000	180,000	155,800	127,300	90,000	5.80	5.25	2.50
PL14	ORANGE	100,000	80,000	200,000	173,200	141,400	100,000	5.80	5.25	2.62

Rated capacities (in pounds) are determined with the sling angle calculated from the vertical.

PL8-PL14 are also available with black tubing. Permanent or removable wear resistant covering available upon request.

WARNING

See page 26-28 for inspection and removal criteria

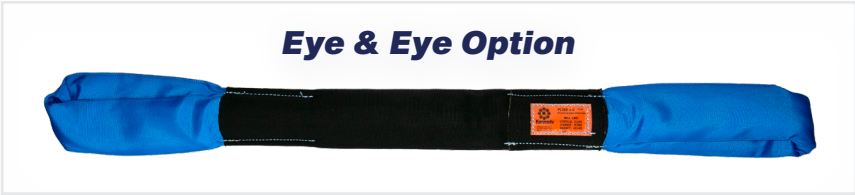

POWER LIFT ROUND SLING TWO LEG SPREADER

Polyester two leg spreaders are useful when the load is equipped with permanent lifting attachments. For such applications, two leg spreaders are lightweight, easy to use, and economical.

Stock #	Color Code	60° 	45° 	30° 	Master Link Size (")	Hook Size (WLL)
OL-2-PL1	PURPLE	4,500	3,700	2,600	3/4	1.5t Web Sling Hook
OL-2-PL2	GREEN	9,200	7,500	5,300	7/8	3t Web Sling Hook
OL-2-PL3	YELLOW	14,500	11,900	8,400	1	5t Web Sling Hook
OL-2-PL4	TAN	18,400	15,000	10,600	1-1/4	5t Web Sling Hook
OL-2-PL5	RED	22,900	18,700	13,200	1-1/2	*
OL-2-PL6	WHITE	29,100	23,800	16,800	1-3/4	*
OL-2-PL7	BLUE	36,700	30,000	21,200	1-3/4	*
OL-2-PL8	ORANGE	43,300	35,400	25,000	2	*



Rated capacities (in pounds) are determined with the sling angle calculated from the vertical.

*Available when a connection fitting is used for attaching the hook to the eye. Please contact our sales team for additional information.

Additional sizes and permanent or removable wear resistant coverings are available upon request. Please contact our sales team for special requirements. For sizes greater than PL8, please consider using an HMPE Sling (pg 39).

Hook Options



 WARNING 	See page 26-28 for inspection and removal criteria
--	---



POWER LIFT ROUND SLING THREE LEG SPREADER

Polyester three leg spreaders are useful when the load is equipped with permanent lifting attachments. For such applications, three leg spreaders are lightweight, easy to use, and economical.

Stock #	Color Code	60° 	45° 	30° 	Master Link Size (")	Hook Size (WLL)
OL-3-PL1	PURPLE	6,800	5,500	3,900	1	1.5t Web Sling Hook
OL-3-PL2	GREEN	13,800	11,200	8,000	1	3t Web Sling Hook
OL-3-PL3	YELLOW	21,800	17,800	12,600	1-1/4	5t Web Sling Hook
OL-3-PL4	TAN	27,500	22,500	15,900	1-1/2	5t Web Sling Hook
OL-3-PL5	RED	34,300	28,000	19,800	1-3/4	*
OL-3-PL6	WHITE	43,600	35,600	25,200	2	*
OL-3-PL7	BLUE	55,100	45,000	31,800	2	*
OL-3-PL8	ORANGE	64,900	53,000	37,500	2-1/2	*





*Available when a connection fitting is used for attaching the hook to the eye. Please contact our sales team for additional information. Rated capacities (in pounds) are determined with the sling angle calculated from the vertical.

Additional sizes and permanent or removable wear resistant coverings are available upon request. Please contact our sales team for special requirements. For sizes greater than PL8, please consider using an HMPE Sling (pg 39).

 WARNING 	See page 26-28 for inspection and removal criteria
--	--

POWER LIFT ROUND SLING FOUR LEG SPREADER

Polyester four leg spreaders are useful when the load is equipped with permanent lifting attachments. For such applications, four leg spreaders are lightweight, easy to use, and economical.

Stock #	Color Code	60° 	45° 	30° 	Master Link Size (")	Hook Size (WLL)
OL-4-PL1	PURPLE	9,000	7,400	5,200	1	1.5t Web Sling Hook
OL-4-PL2	GREEN	18,400	15,000	10,600	1-1/4	3t Web Sling Hook
OL-4-PL3	YELLOW	29,100	23,800	16,800	1-1/2	5t Web Sling Hook
OL-4-PL4	TAN	36,700	30,000	21,200	2	5t Web Sling Hook
OL-4-PL5	RED	45,700	37,300	26,400	2	*
OL-4-PL6	WHITE	58,200	47,500	33,600	2-1/2	*
OL-4-PL7	BLUE	73,400	60,000	42,400	2-1/2	*
OL-4-PL8	ORANGE	86,600	70,700	50,000	2-3/4	*



*Available when a connection fitting is used for attaching the hook to the eye. Please contact our sales team for additional information. Rated capacities (in pounds) are determined with the sling angle calculated from the vertical.

Additional sizes and permanent or removable wear resistant coverings are available upon request. Please contact our sales team for special requirements. For sizes greater than PL8, please consider using an HMPE Sling (pg 39).

 WARNING 	See page 26-28 for inspection and removal criteria
--	---



KWRS POWER LIFT ROUND SLINGS

Round slings are fabricated with high quality, high strength 100% polyester fibers. These fibers are encased in a seamless, double-walled polyester jacket, providing maximum protection to the inner load-bearing fibers. These slings provide an exceptionally flexible rigging tool that grips the load without marring the load surface.

Round Sling Features:

- Max working temp: 194° F
- No loss of strength when wet
- Seamless with double jacket
- Resists most acids
- Lightweight - easy to use, handle and store
- Only 3% elongation
- Endless construction rotates wear points
- Color coded

Sling Selection Consideration:

Some notable polyester round sling characteristics include the following:

- Lightweight, flexible, and easy to handle and rig
- Polyester round sling elongation at rated capacity is approximately 3%—less than that of comparable nylon or polyester web slings
- Wear points can be easily rotated to extend sling life
- Polyester round sling are easy to inspect
- Polyester round slings are less damaging on contacting load surfaced than metal type slings
- The exterior cover aids in protecting the load bearing core yarn
- Additional permanent or removable wear resistant coverings can be purchased for additional protection

Sling Inspection:

How to Inspect Slings

To detect possible damage, you should perform a visual inspection of the entire sling, and also feel along its entire length, as some damage may be felt more than seen. You should look and feel for any of the types of conditions seen on page 28.

What to Do If You Identify Damage In a Sling

If you identify **ANY** of these types of damage in a sling, remove it from service immediately even if the damage you feel or see is not as extensive as shown in the pictures on page 28. Slings that are removed from service must be destroyed and rendered completely unusable.

ASME B30.9-5.9 - Frequency of Inspection

A 3 stage procedure is recommended to help ensure that round slings are inspected with appropriate frequency.

- 1. Initial Inspection** - Slings must be inspected by a designated person as soon as they are received. This ensures that the correct round sling has been received, is undamaged, and meets the requirements for its intended use.
- 2. Frequent Inspection** - When round slings are being used where they are not being exposed to any severe service conditions, the frequency of this sling inspection interval may be reduced to once each day or shift, done prior to sling use. A qualified person must be monitoring the application to verify that the slings are not being exposed to any conditions that could cause a rapid rate of sling degradation during the work shift.
- 3. Periodic Inspection** - Every sling must be inspected “periodically” by a qualified and designated person. The frequency of periodic inspections is based on the sling’s actual or expected frequency of use, severity of service conditions, and the nature of the work performed with the sling.

REMOVAL CRITERIA

ASME B30.9-5.9 - Possible Defects

A sling shall be removed from service if any defects such as the following are visible:

- Holes, tears, cuts, embedded particles, excessive abrasive wear or snags that expose the core fibers of the round sling
- If round sling identification tag is missing or not readable
- If round sling has been tied into one or more knots or has been joined by knotting
- Melting, charring or weld spatter on any part of the round sling
- Acid or alkali burns of the round sling
- Broken or worn stitching in the cover that exposes the core fibers
- Distortion, excessive pitting, corrosion or other damage to fitting(s)
- Any evidence of a broken core yarn(s) present in the form of a substantial reduction of core yarn within any area of the round sling and/or by a substantial accumulation of core yarn bundle within any section of the round sling
- Any conditions which cause doubt as to the strength of the round sling



TYPES OF DAMAGE

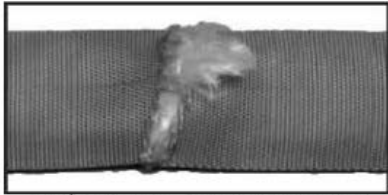

Holes/tears/cuts in cover;
exposed/damaged yarns

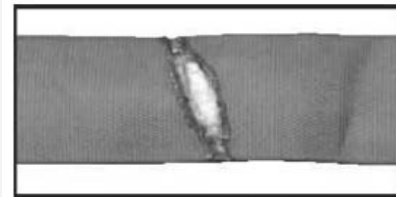

Melting or charring

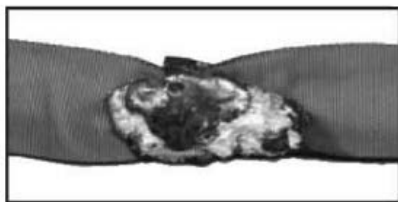

Acid/alkali burns

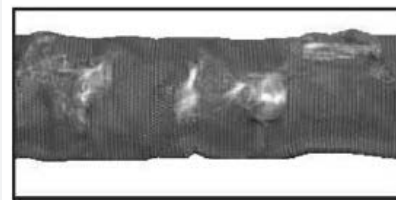

Snags/punctures



Weld spatter

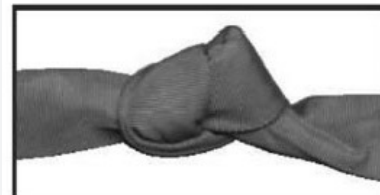

External knots



Bunched/wadded yarns

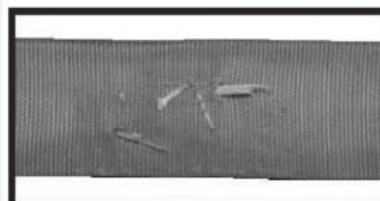

Embedded materials



WARNING



Failure to follow the care, use, and inspection instructions of a sling could result in severe personal injury or death.

Do NOT exceed rated capacities.

PROTECTING SLINGS FROM DAMAGE

Mechanical Considerations

Round slings in contact with edges, corners, or protrusions **MUST ALWAYS** be protected with materials of sufficient strength, thickness, and construction to prevent sling damage.

- Round slings should be protected from abrasive surfaces.
- Determine the weight of the load. Round slings shall not be loaded in excess of the rated capacity. Consideration shall be given to the sling angle, which affects rated capacity.
- Select round slings that have suitable characteristics for the type of load, hitch and environment.
- Round slings with fittings that are used in a choker hitch shall be of sufficient length to ensure that the choking action is on the round sling and never on the fitting or sling tag.
- The openings in fittings shall be the proper shape and size to ensure that the fittings will seat properly on the round sling, crane hook, or other attachments.
- Round slings should not be dragged on the floor or over an abrasive surface.
- A half twist (up to 180°) may be applied to any round sling to facilitate its attachment. However, round slings must not be twisted further or be tied into knots to shorten their length or be joined to another round sling by knotting them together. Round slings shall be shortened, lengthened, or adjusted only by methods approved by the manufacturer.
- Round slings should not be pulled from under loads when the load is resting on the round sling. Place blocks under load prior to setting down the load to allow removal of the sling, if applicable.
- Round slings shall not be used to pull against stuck, snagged, or restrained objects.
- Do not drop round slings equipped with metal fittings.
- Round slings that are damaged shall not be used.
- Round slings shall be hitched in a manner providing control of the load. Round slings used in a basket hitch shall have the load balanced to prevent slippage.
- Shock loading shall be avoided.



continued

- Load applied to a hook shall be centered in the bowl of the hook to prevent point loading.
- During use, personnel shall be alert for possible snagging of the load or round sling.
- When using a basket hitch, round sling legs (branches) shall contain or support the load from the sides above the center of gravity.
- Tags and labels should be kept away from the load, hook, and point of choke.
- Round slings should not be constricted or bunched between the ears of a clevis or shackle or in a hook. When a round sling is used with a shackle, it is recommended that it be used (rigged) in the bow of the shackle. When this is not possible, protect the sling connection areas from damage.
- For lifts using multiple slings, or multiple-leg bridle slings, on non-symmetrical loads, an analysis by a qualified person should be performed to prevent overloading of any leg.
- Do not use hooks, shackles, or other hardware that have edges or surfaces that could damage the sling.
- Do not run or drive over slings with a vehicle or other equipment.

Environmental Considerations

Environmental factors, such as an exposure to sunlight, dirt, or gritty-type matter and cyclical changes in temperature and humidity, can result in an accelerated deterioration of round slings. The rate of this deterioration will vary with the level of exposure to these conditions.

Temperature Limits – Do not expose round slings to sources of heat damage or weld splatter.

- Polyester round slings shall not be used in contact with objects or in environments at temperatures in excess of 194° F (90° C), or at temperatures below minus 40° F (-40° C).
- For short term, single exposure applications at temperatures elevated slightly higher than the above values, sling users may consult with the sling manufacturer and seek written approval to allow this practice.

Chemical Environment – Do not expose slings to damaging chemicals. Chemically active environments can affect the strength of round slings in varying degrees ranging from little to total degradation. The round sling manufacturer or a qualified person should be consulted before round slings are used in a chemically active environment. Each chemical application shall be evaluated, taking into consideration the following:

- Type of chemical, such as acid or alkalis
- Exposure conditions, i.e., liquid, vapor, mist
- Concentration
- Temperature
- Duration of exposure

Round slings incorporating aluminum fittings shall not be used where fumes, vapors, sprays, mists, or liquids of alkalis and/or acids are present, unless the compatibility of these material is verified.

Electrical Environment – Do not expose round slings to an electrically active environment or use them as an electrical insulator in an energized electrical environment unless a qualified person has determined the insulation requirements necessary for the application and has established that use of a particular sling will meet the requirements for their purpose. Otherwise, severe injury or death can result from shock, burns, or electrocution. Consideration shall also be given to the effect of other environmental factors, including humidity, on the sling's capability for this purpose.

Sling Storage and Maintenance

Round slings should be stored in a cool, dry, and dark place to prevent loss of strength when not in use. Round slings shall not be stored in chemically active areas.

There shall be no repairs of load bearing fibers. Repairs to the protective covers shall be done only by the original manufacturer or their appointed agent. When slings are repaired by someone other than the original manufacturer, the sling should be tagged to identify the repair agent.

Only round slings which can be identified from the information on the identification tag shall be repaired.

All repaired round slings shall be proof tested to a minimum of 2 times the rated capacity before being put back into service. Certification of proof test should be provided.



continued

PROPER HITCHING METHODS FOR ROUND SLINGS

Vertical Hitch:

A method of rigging in which the load is attached to one end of the sling, such as by means of a hook or shackle, and the other end of the sling is attached to the lifting device. This hitch is sometimes also called a straight-line hitch.



Choker Hitch:

A method of rigging in which the sling is passed around the load and then through itself and then attached to the lifting device.

Double Wrapped Choker Hitch:

A method of rigging in which the sling is passed around the load twice and then through itself and then attached to the lifting device. The double wrap hitch or the double wrap choker hitch provides full 360 degree contact with the load.

WARNING: When using a double-wrap hitch, avoid overlapping slings, as it can lead to uneven load distribution, sling damage, and compromised safety.

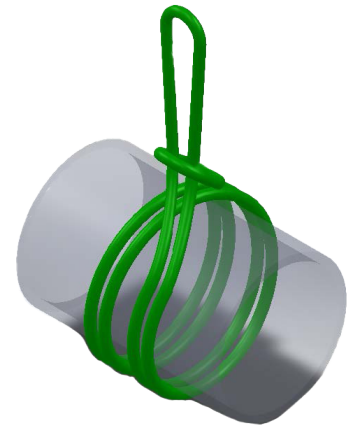



Basket Hitch:

A method of rigging in which the sling is passed around the load and both ends are attached to the lifting device.

Double Wrapped Basket Hitch:

A method of rigging similar to the basket hitch except that the sling is passed around the load twice.

WARNING: When using a double-wrap hitch, avoid overlapping slings, as it can lead to uneven load distribution, sling damage, and compromised safety.



Bridle (Multi-leg) Hitch:

A method of rigging as a 2-leg bridle, in which the load is attached to the legs of a bridle assembly. 2-, 3- and 4-leg slings are commonly used types of bridle slings.

Length Tolerances For New Round Slings

Round Sling Size / Vertical Capacity Range	Tolerance*
30,000 lbs. or Less	\pm (1" + 1% of sling length)
Higher than 30,000 lbs., up to 90,000 lbs.	\pm (2.0" + 1% of sling length)
Higher than 90,000 lbs., up to 175,000 lbs.	\pm (3.0" + 1% of sling length)

For matching length slings, please contact a salesperson.



SELECTION OF PROPER CONNECTION HARDWARE

Effective Contact Width between the Sling and Connection Hardware

Connection to Flat-Bottom Surfaced Hardware: Such hardware connections include pins, bolts, and trunnions. The value of the effective contact width is equal to the opening width or spread of the sling at the connection area. Please note, however, that the effective contact width will never exceed the natural flattening width of the sling.

Connection to Round-Bottom (curved) Surfaced Hardware: Such hardware connections include links, hooks, or the bow ends of shackles. To determine the value of the effective contact width, multiply the inside opening width of the hardware by a factor of 0.75. For connections to the base of hooks, multiply the value of the radius at the hook base by a factor of 1.5 to determine the effective contact width. Please note, however, that the effective contact width will never exceed the natural flattening width of the sling.

$$\text{Effective Contact Width} = (.75) \times (\text{Shackle Inside Width})$$

Straight Bearing Surface

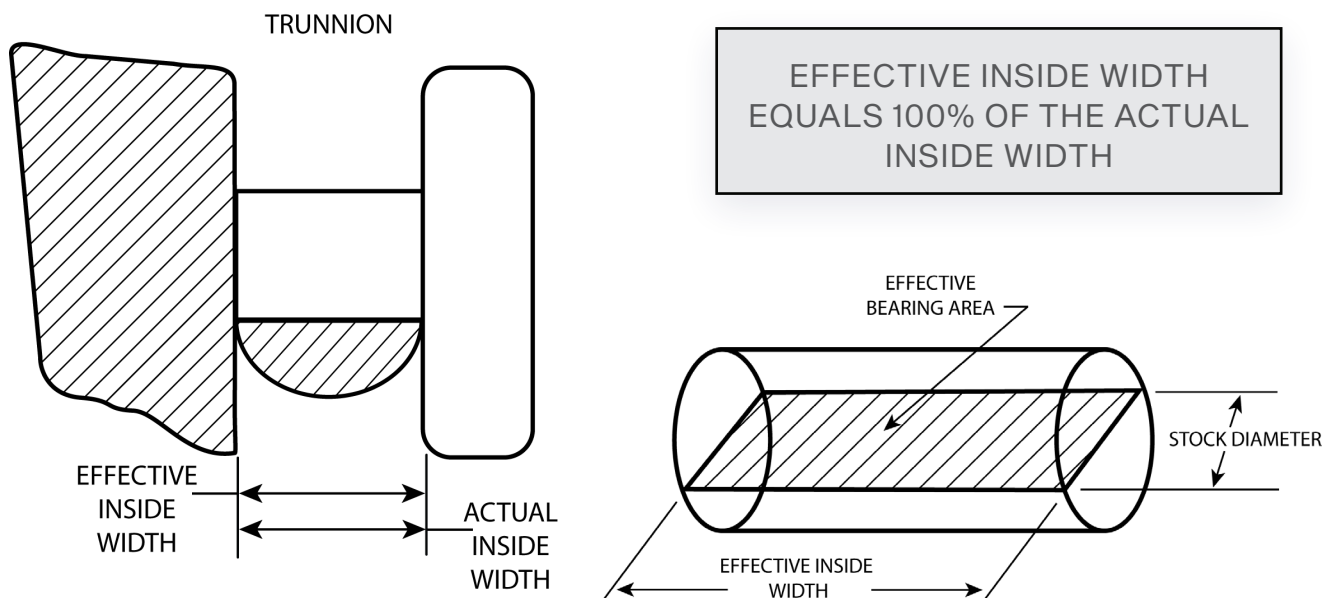

continued

Curved Bearing Surface

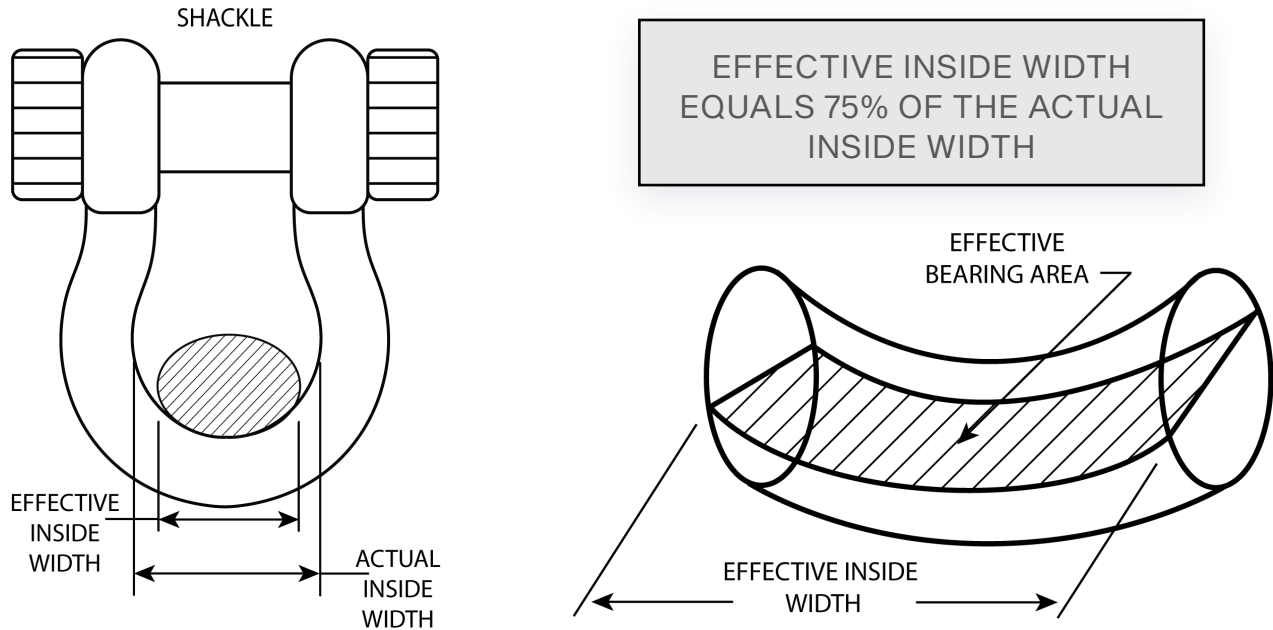

NOTE: Round sling strength is affected by the size of the connection hardware. For special applications wherein a retained design factor of 5 is required to be maintained, contact the sling manufacturer, as a capacity reduction of 20% may be appropriate in order to satisfy this criteria.

Load Bearing Area at the Hardware Connection:

The load bearing area at the hardware connection is determined by multiplying the thickness or stock diameter of the hardware by the effective contact width at the connection.

$$\text{Load Bearing Area} = (\text{Hardware Thickness or Stock Diameter}) \times (\text{Effective Contact Width})$$

Calculating Bearing Stress Values at the Hardware Connection:

The bearing stress value is determined by dividing the amount of loading on the sling by the load bearing area at the hardware connection.

$$\text{Bearing Stress} = \frac{\text{Sling Load Value (lbs.)}}{\text{Load Bearing Area}}$$



continued

Example: A size 3 polyester round sling, rated at 8,400 lbs. in a vertical hitch, is connected using the rounded bow end of a shackle that is smaller in size to that listed in Table 4-6. The shackle has a stock diameter of only .62 inch, and an inside opening width of 2 inches. However, a force of only 6,000 lbs. is applied, noticeably less than the rated capacity of the sling (see figure). Is this use of the selected shackle acceptable?

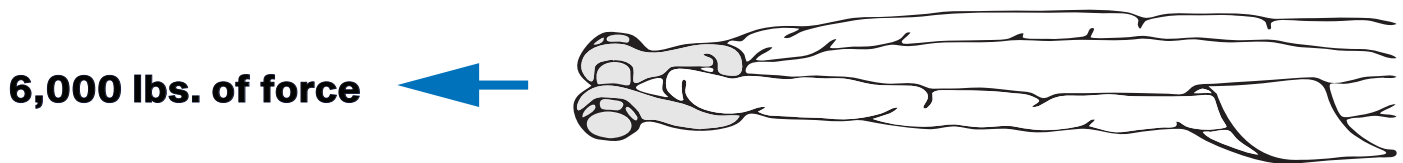

Answer: Since the shackle size is smaller than recommended for a size 3 round sling, we need to establish that the bearing stress value does not exceed 7,000 Lbs. /in² during use. Since the shackle bearing surface is rounded, multiply the width by .75 to determine the effective contact width.

$$\begin{aligned} \text{Effective Contact Width} &= (.75) \times (\text{The shackle inside width}) \\ &= (.75) \times (2 \text{ in.}) = \mathbf{1.5 \text{ in.}} \end{aligned}$$

And

$$\begin{aligned} \text{Load Bearing Area} &= (\text{The shackle inside width}) \times (\text{The effective contact width}) \\ &= (.62 \text{ in.}) \times (1.5 \text{ in.}) = \mathbf{.93 \text{ in.}^2} \end{aligned}$$

$$\begin{aligned} \text{Bearing Stress Value} &= (\text{The applied force}) / (\text{Load bearing area}) \\ &= (6,000 \text{ lbs.}) / (.93 \text{ in.}^2) \\ &= \mathbf{6,641 \text{ lbs.} / \text{in.}^2} \end{aligned}$$

Therefore, since the bearing stress value is less than 7,000 Lbs./in² during use, **the selected shackle size is suitable for use.**

SUPER POWER LIFT ROUND SLINGS

Kennedy Wire Rope & Sling offers Super Power Lift Round Slings made to ISO-9001 quality standards. Our High Performance Round Slings are made from High Molecular Weight Polyethylene (HMPE) fibers encapsulated in a durable, double layer cover. HMPE fiber is significantly lighter than equivalent strength polyester round slings or wire rope, allowing for fewer riggers to perform the job in less time. With 75% less elongation than comparable polyester slings, overhead clearance is maximized in low headroom situations.

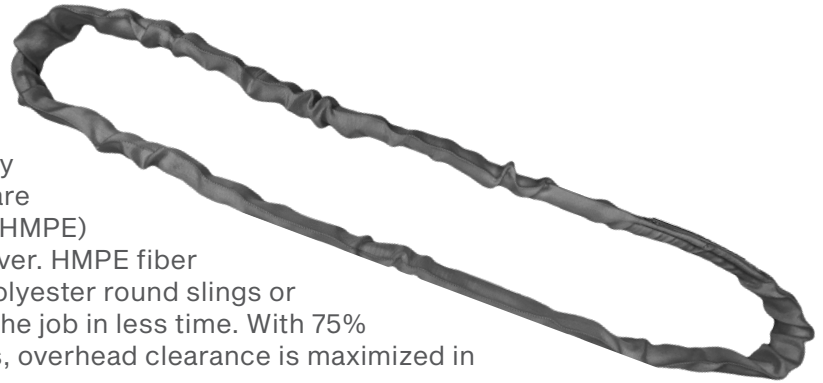

Stock #	Vertical	Choker	Basket Hitches				Weight/Ft.	Width (")
			90°	60°	45°	30°		
SPL-10	10,000	8,000	20,000	17,320	14,140	10,000	.38	2
SPL-15	15,000	12,000	30,000	25,980	21,210	15,000	.48	2
SPL-20	20,000	16,000	40,000	34,640	28,280	20,000	.55	2
SPL-25	25,000	20,000	50,000	43,300	35,350	25,000	.63	3
SPL-30	30,000	24,000	60,000	51,960	42,420	30,000	.75	3
SPL-40	40,000	32,000	80,000	69,280	56,560	40,000	.88	3
SPL-50	50,000	40,000	100,000	86,600	70,700	50,000	1.13	4
SPL-60	60,000	48,000	120,000	103,920	84,840	60,000	1.25	4
SPL-70	70,000	56,000	140,000	121,240	98,980	70,000	1.38	4
SPL-85	85,000	68,000	170,000	147,220	120,190	85,000	1.75	5
SPL-100	100,000	80,000	200,000	173,200	141,400	100,000	2.00	5
SPL-125	125,000	100,000	250,000	216,500	176,750	125,000	2.50	5
SPL-135	135,000	108,000	270,000	233,820	190,890	135,000	3.13	7
SPL-150	150,000	120,000	300,000	259,800	212,100	150,000	3.50	7
SPL-175	175,000	140,000	350,000	303,100	247,450	175,000	4.25	7
SPL-200	200,000	160,000	400,000	346,400	282,800	200,000	4.75	8
SPL-250	250,000	200,000	500,000	433,000	353,500	250,000	5.75	8
SPL-300	300,000	240,000	600,000	519,600	424,200	300,000	7.00	12

Make Sure All Personnel are Clear of Loads and Alert to Risks, Especially in the "Danger Zone"

NEVER ON



NEVER UNDER



NEVER IN-LINE



Overloaded and/or damaged slings, rigging hardware and/or sling protection may fail, and the unplanned release of tension may:

- strike personnel with deadly recoil and/or impact force.
- become deadly projectiles resulting in SEVERE INJURY or DEATH.



continued

To potentially maximize the performance and service life of Super Power Lift Round Slings, one approach may be the selection and use of wide body shackles. The wide body shackle bow is larger than the diameter of an equivalently rated screw pin anchor shackle. Larger contact diameters or bows increase the size of the sling connection point, which effectively decreases connection point pressure. This has been proven in decades of use and testing of polyester round slings, and may prove to be beneficial with Super Power Lift Round Slings. Ask a sales person about wide body shackles.

<p>55T SPAS – 2.5” Sling WLL – 100,000 Lbs. CP Pressure – 6,622 Lbs.</p>	<p>55T WBS – 4.5” Sling WLL – 100,000 Lbs. CP Pressure – 3,810 Lbs.</p>

Round sling tags must include the following mandatory information. If any of the mandatory information is missing or illegible, the round sling must be **immediately** removed from service. Round sling tags shall be permanently marked with the following information:

- Manufacturer’s name or trademark, or if repaired, the entity performing repairs
- Manufacturer’s code or stock number
- Rated load for at least one hitch and the angle upon which it is based
- Core material
- Cover material, if different than core material
- Number of legs, if more than one

High Performance Round Sling tags feature ratings for choker, vertical, and basket hitches as appropriate for the sling type. Symbols are used to indicate the angle of loading on which work load limits are based. These symbols effectively transcend language, literary, and comprehension impediments. These symbols are used on sling tags and within work load limit charts.

ASME B30.9-7 – HIGH PERFORMANCE ROUND SLING REMOVAL CRITERIA

High Performance Fiber Round slings shall be removed from service if any of the following conditions are present:

- | | |
|--|--|
| <ul style="list-style-type: none"> • Missing or illegible sling identification • Acid or caustic burns • Evidence of heat damage. • Holes, tears, cuts abrasive wear, or snags that expose the core yarns • Broken damaged core yarns • Weld splatter that exposes core yarns • Knots in the round sling, except for core yarn knots inside the cover installed by the manufacturer during the fabrication process • Fittings that are pitted, corroded, cracked, bent, twisted, gouged, or broken | <ul style="list-style-type: none"> • For hooks, removal criteria as stated in ASME B30.10 • For rigging hardware, removal criteria as stated in ASME B30.26 • Other conditions, including visible damage, that cause doubt as to the continued use of the sling • Broken or worn stitching in the cover which exposes the core yarns • Bunched or wadded core yarn • Empty or void areas throughout the sling, determined though tactile inspection, that do not contain an even or uniform distribution of core yarns |
|--|--|



HMPE SLINGS

HMPE fiber slings represent a cutting-edge lifting solution, combining lightweight construction with exceptional strength and durability. Engineered from ultra high molecular weight polyethylene fibers, these slings are ideal for demanding lifting applications where performance, safety, and efficiency are paramount.

Key advantages of HMPE slings include:

- **High Strength-to-Weight Ratio:** HMPE fibers provide unparalleled lifting capacity while remaining significantly lighter than traditional slings, reducing operator fatigue and easing transportation.
- **Low Stretch:** Minimal elongation under load ensures precision and stability during lifts.
- **Exceptional Durability:** Resistant to abrasion, UV exposure, chemicals, and moisture, HMPE slings perform reliably in harsh environments, including marine and offshore applications.
- **Load Protection:** The soft, yet strong, material reduces the risk of surface damage to delicate or high-value loads.
- **Enhanced Safety:** Lightweight construction reduces handling hazards, and the material's strength minimizes the risk of sling failure under rated loads.





Commonly used in industries such as shipping, construction, aerospace, and heavy manufacturing, HMPE slings excel in critical applications requiring superior performance and reliability. Proper inspection, adherence to load limits, and compliance with safety standards are essential for ensuring safe and effective use.



HMPE EYE & EYE SLINGS

! WARNING ! See page 49 for removal criteria

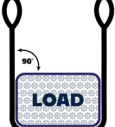
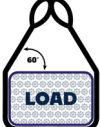

Diameter (")	Vert 	Choker 	90° 	60° 	45° 	30° 	Circ. (")	MBL (lbs)
1/4 (6 mm)	1,600	1,120	3,200	2,770	2,260	1,600	3/4	8,000
5/16 (8 mm)	2,340	1,630	4,680	4,050	3,300	2,340	15/16	11,700
3/8 (9 mm)	3,500	2,450	7,000	6,060	4,940	3,500	1-1/8	17,500
7/16 (11 mm)	4,200	2,940	8,400	7,270	5,930	4,200	1-1/4	21,000
1/2 (12 mm)	6,260	4,380	12,500	10,800	8,850	6,260	1-1/2	31,300
9/16 (14 mm)	7,580	5,300	15,100	13,100	10,700	7,580	1-3/4	37,900
5/8 (16 mm)	10,200	7,190	20,500	17,800	14,500	10,200	2	51,400
3/4 (18 mm)	13,700	9,590	27,400	23,700	19,300	13,700	2-1/4	68,500
13/16 (20 mm)	14,800	10,300	29,600	25,600	20,900	14,800	2-1/2	74,000
7/8 (22 mm)	18,500	12,900	37,000	32,000	26,100	18,500	2-3/4	92,600
1 (24 mm)	22,000	15,400	44,000	38,100	31,100	22,000	3	110,000
1-1/16 (26 mm)	25,800	18,000	51,600	44,700	36,500	25,800	3-1/4	129,200
1-1/8 (28 mm)	29,400	20,500	58,800	50,900	41,500	29,400	3-1/2	147,000
1-1/4 (30 mm)	33,000	23,100	66,000	57,100	46,600	33,000	3-3/4	165,000
1-5/16 (32 mm)	39,200	27,400	78,400	67,800	55,400	39,200	4	196,000
1-1/2 (36 mm)	44,200	30,900	88,400	76,500	62,500	44,200	4-1/2	221,000
1-5/8 (40 mm)	58,200	40,700	116,400	100,800	82,300	58,200	5	291,000
1-3/4 (44 mm)	62,800	43,900	125,600	108,700	88,800	62,800	5-1/2	314,000
2 (48 mm)	71,000	49,700	142,000	122,900	100,400	71,000	6	355,000
2-1/8 (52 mm)	85,600	59,900	171,200	148,200	121,000	85,600	6-1/2	428,000
2-1/4 (56 mm)	96,200	67,300	192,400	166,600	136,000	96,200	7	481,000
2-1/2 (60 mm)	106,000	74,200	212,000	183,500	149,900	106,000	7-1/2	530,000
2-5/8 (64 mm)	119,200	83,400	238,400	206,400	168,500	119,200	8	596,000
2-3/4 (68 mm)	132,000	92,400	264,000	228,600	186,600	132,000	8-1/2	660,000
3 (72 mm)	156,000	109,200	312,000	270,100	220,600	156,000	9	780,000
3-1/8 (76 mm)	170,000	119,000	340,000	294,400	240,400	170,000	9-1/2	850,000
3-1/4 (80 mm)	188,000	131,600	376,000	325,600	265,800	188,000	10	940,000
3-1/2 (84 mm)	221,600	155,100	443,200	383,800	313,300	221,600	10-1/2	1,108,000
3-5/8 (88 mm)	250,000	175,000	500,000	433,000	353,500	250,000	11	1,250,000
3-3/4 (92 mm)	263,400	184,300	526,000	456,200	372,500	263,400	11-1/2	1,317,000

*Rated capacities (in pounds) are based on a design factor of 5:1 and determined with the sling angle calculated from the vertical.

Chart continued on next page

Dia. (")	Vert	Choker	90°	60°	45°	30°	Circ. (")	MBL (lbs)
4 (96 mm)	304,000	212,800	608,000	526,000	429,900	304,000	12	1,520,000
4-1/8 (100 mm)	324,400	227,000	648,000	561,000	458,700	324,400	12-1/2	1,622,000
4-1/4 (104 mm)	339,400	237,500	678,000	587,000	479,900	339,400	13	1,697,000
4-1/2 (108 mm)	365,400	255,700	730,000	632,000	516,000	365,400	13-1/2	1,827,000
4-5/8 (112 mm)	376,000	263,200	752,000	651,000	531,000	376,000	14	1,880,000
4-3/4 (116 mm)	385,400	269,700	770,000	667,000	545,000	385,400	14-1/2	1,927,000
5 (120 mm)	413,900	289,700	827,000	716,000	585,000	413,900	15	2,069,500
5-1/8 (124 mm)	442,400	309,600	884,000	766,000	625,000	442,400	15-1/2	2,212,000
5-1/4 (128 mm)	471,000	329,700	942,000	815,000	666,000	471,000	16	2,355,000
5-1/2 (132 mm)	499,500	349,600	999,000	865,000	706,000	499,500	16-1/2	2,497,500
5-5/8 (136 mm)	528,000	369,600	1,056,000	914,000	746,000	528,000	17	2,640,000
5-3/4 (140 mm)	556,000	389,500	1,113,000	963,000	787,000	556,000	17-1/2	2,782,500

Minimum Break Load (MBL) in pounds is determined using spliced test samples in accordance with Cordage Institute 1500-02 - Test Method for Fiber Ropes.

Minimum sling length on fabricated eye & eye slings assumes 1) a compressed minimum eye length of 6.75 times the rope diameter in inches, and 2) a clear span area between splices of 10 times Kennedy rope circumference in feet.

The recommended design factor (DF) of 5:1 on this chart is based on several existing sling standards including ASME B30.9. This design factor takes into account various factors including the use of Ultra High Molecular Weight Polyethylene (HMPE) fiber which is extremely durable and resistant to repeated high loads. HMPE rope slings have and can be used with different DF ratios; however, this is a decision which must be made by a qualified person in conjunction with the rope manufacturer.

We recommend the use of wear protection around choking points. Please consult KWRS if you require the use of our fiber rope slings in a choker hitch at a lifting angle of less than 120°, following ASME B30.9 guidelines.

Bending Guidance for Eye & Eye Slings

In theory, a sling used in a basket configuration could have twice the working load as a sling in a vertical configuration because two ropes are now holding the load instead of one. However, the decrease in tensile stress is partially offset by an increase in bending stress. The magnitude of this bending stress is dependent on the size and shape of the contact surface. Users must account for the bending strength loss with an efficiency factor as shown below in the reduced basket capacity calculation.

The bending efficiency reduces as the D:d ratio is reduced. Example: a 5:1 D:d ratio provides 80% efficiency.

Reduced Basket Capacity Calculation

$C = B \times e$

C = Reduced Basket Capacity due to bending efficiency reduction

B = Rated Basket Capacity with consideration of horizontal sling fleet angle

e = Bending efficiency percentage

- Represents a contact surface that is equal to or greater than the rope diameter
- Represents a contact surface with a D:d ratio of one or greater. Refer to the Efficiency Table for deductions as needed.

Efficiency Table	
D:d Ratio	eff % (e)
25:1	100.0%
8:1	82.5%
5:1	80.0%
3:1	75.0%
2:1	72.5%
1:1	65.0%



HMPE ENDLESS GROMMET SLINGS

HMPE endless grommet slings offer greater strength than eye and eye slings without increasing rope diameter and can be made shorter since no extra material is needed for eyes. Their minimum breaking load depends on the pin diameter they are mounted on.



! WARNING ! See page 49 for removal criteria

Dia. (in.)	Vert	Choker	90°	60°	45°	30°	Circ. (in.)	MBL (lbs.)
1/4 (6 mm)	2,640	1,120	4,750	4,110	3,360	2,370	3/4	13,200
5/16 (8 mm)	3,860	1,630	6,940	6,010	4,910	3,470	15/16	19,305
3/8 (9 mm)	5,770	2,450	10,300	9,000	7,350	5,190	1-1/8	28,875
7/16 (11 mm)	6,930	2,940	12,400	10,800	8,820	6,230	1-1/4	34,650
1/2 (12 mm)	10,300	4,380	18,500	16,100	13,100	9,290	1-1/2	51,645
9/16 (14 mm)	12,500	5,300	22,500	19,400	15,900	11,200	1-3/4	62,535
5/8 (16 mm)	16,900	7,190	30,500	26,400	21,500	15,200	2	84,810
3/4 (18 mm)	22,600	9,590	40,600	35,200	28,700	20,300	2-1/4	113,025
13/16 (20 mm)	24,400	10,300	43,900	38,000	31,000	21,900	2-1/2	122,100
7/8 (22 mm)	30,500	12,900	55,000	47,600	38,800	27,500	2-3/4	152,790
1 (24 mm)	36,300	15,400	65,300	56,500	46,200	32,600	3	181,500
1-1/16 (26 mm)	42,600	18,000	76,700	66,400	54,200	38,300	3-1/4	213,180
1-1/8 (28 mm)	48,500	20,500	87,300	75,600	61,700	43,600	3-1/2	242,550
1-1/4 (30 mm)	54,400	23,100	98,000	84,800	69,300	49,000	3-3/4	272,250
1-5/16 (32 mm)	64,600	27,400	116,400	100,800	82,300	58,200	4	323,400
1-1/2 (36 mm)	72,900	30,900	131,200	113,600	92,800	65,600	4-1/2	364,650
1-5/8 (40 mm)	96,000	40,700	172,800	149,600	122,200	86,400	5	480,150
1-3/4 (44 mm)	103,600	43,900	186,500	161,500	131,800	93,200	5-1/2	518,100
2 (48 mm)	117,100	49,700	210,800	182,600	149,100	105,400	6	585,750
2-1/8 (52 mm)	141,200	59,900	254,200	220,100	179,700	127,100	6-1/2	706,200
2-1/4 (56 mm)	158,700	67,300	285,700	247,400	202,000	142,800	7	793,650
2-1/2 (60 mm)	174,900	74,200	314,800	272,600	222,600	157,400	7-1/2	874,500
2-5/8 (64 mm)	196,600	83,400	354,000	306,500	250,300	177,000	8	983,400
2-3/4 (68 mm)	217,800	92,400	392,000	339,500	277,200	196,000	8-1/2	1,089,000
3 (72 mm)	257,400	109,200	463,300	401,200	327,600	231,600	9	1,287,000
3-1/8 (76 mm)	280,500	119,000	504,000	437,200	357,000	252,400	9-1/2	1,402,500
3-1/4 (80 mm)	310,200	131,600	558,000	483,500	394,800	279,100	10	1,551,000
3-1/2 (84 mm)	365,600	155,100	658,000	569,000	465,300	329,000	10-1/2	1,828,200
3-5/8 (88 mm)	412,500	175,000	742,000	643,000	525,000	371,200	11	2,062,500
3-3/4 (92 mm)	434,600	184,300	782,000	677,000	553,000	391,100	11-1/2	2,173,050

One splice in one leg vertical, choker and basket hitches. Basket hitch at varying angles.

*Rated capacities (in pounds) are based on a Design Factor of 5:1 and a D:d of 8:1. Ratings are determined with the sling angle calculated from the vertical.

Chart continued on next page



Dia. (in.)	Vert	Choker	90°	60°	45°	30°	Circ. (in.)	MBL (lbs.)
4 (96 mm)	501,000	212,800	902,000	781,000	638,000	451,400	12	2,508,000
4-1/8 (100 mm)	535,000	227,000	963,000	834,000	681,000	481,700	12-1/2	2,676,300
4-1/4 (104 mm)	560,000	237,500	1,008,000	872,000	712,000	504,000	13	2,800,050
4-1/2 (108 mm)	602,000	255,700	1,085,000	939,000	767,000	542,000	13-1/2	3,014,550
4-5/8 (112 mm)	620,000	263,200	1,116,000	967,000	789,000	558,000	14	3,102,000
4-3/4 (116 mm)	635,000	269,700	1,144,000	991,000	809,000	572,000	14-1/2	3,179,550
5 (120 mm)	682,000	289,700	1,229,000	1,064,000	869,000	614,000	15	3,414,675
5-1/8 (124 mm)	729,000	309,600	1,313,000	1,137,000	929,000	656,000	15-1/2	3,649,800
5-1/4 (128 mm)	777,000	329,700	1,398,000	1,211,000	989,000	699,000	16	3,885,750
5-1/2 (132 mm)	824,000	349,600	1,483,000	1,284,000	1,049,000	741,000	16-1/2	4,120,875
5-5/8 (136 mm)	871,000	369,600	1,568,000	1,358,000	1,108,000	784,000	17	4,356,000
5-3/4 (140 mm)	918,000	389,500	1,652,000	1,431,000	1,168,000	826,000	17-1/2	4,591,125

This MBL includes a 10% reduction due to 55:45% load sharing. Minimum Break Load (MBL) in pounds is determined using spliced test samples in accordance with Cordage Institute 1500-02 - Test Method for Fiber Ropes.

Specifications for endless loop (grommet) HMPE rope slings assume one end-to-end splice. The length of splice determines the minimum length of a grommet sling.

The recommended design factor (DF) of 5:1 on this chart is based on several existing sling standards including ASME B30.9. This design factor takes into account various factors including the use of Ultra High Molecular Weight Polyethylene (HMPE) fiber which is extremely durable and resistant to repeated high loads. HMPE rope slings have and can be used with different DF ratios: however, this is a decision which must be made by a qualified person in conjunction with the rope manufacturer.

Please consult KWRS if you require the use of our fiber rope slings in a choker hitch at a lifting angle of less than 120°, following ASME B30.9 guidelines.

Bending Guidance for Endless Grommet Slings

In theory, a sling used in a basket configuration could have twice the working load as a sling in a vertical configuration because there are double the number of supporting strands. However, the decrease in tensile stress is partially offset by an increase in bending stress. The magnitude of this bending stress is dependent on the size and shape of the contact surface. Users must account for the bending strength loss with an efficiency factor as shown below in the reduced basket capacity calculation.

The bending efficiency reduces as the D:d ratio is reduced. Example: a 5:1 D:d ratio provides 97% efficiency.

Reduced Basket Capacity Calculation
 $C = B \times e$
C = Reduced Basket Capacity due to bending efficiency reduction
B = Rated Basket Capacity with consideration of horizontal sling fleet angle
e = Bending efficiency percentage

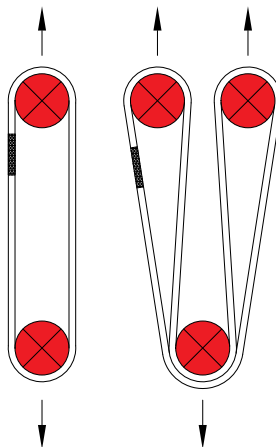

Represents a contact surface with a D:d ratio of one or greater. Refer to the Efficiency Table for deductions as needed.

Efficiency Table	
D:d Ratio	eff % (e)
8:1	100.0%
5:1	97.0%
3:1	91.0%
2:1	88.0%
1:1	79.0%



HMPE FIBER VS STEEL

HMPE fiber ropes and slings have become increasingly popular as replacements for steel wire ropes in load handling. These modern, high-strength synthetic fibers offer remarkable durability without the risks of rust or corrosion. They remain unaffected by both salt and fresh water, and can be safeguarded against abrasion, cutting, and heat damage. Additionally, they are easy to inspect and repair.

1. **Weight Reduction:** They are 1/7 the weight of comparable steel wire rope sling.
2. **Rigging Efficiency:** The lightweight nature reduces rigging time.
3. **Ease of Handling:** Their flexibility and softness make them easier and safer to handle.
4. **Cost Savings:** Reduced handling, transportation, and storage costs.
5. **Repurposing:** Splice into different lengths / configurations throughout life of the sling.

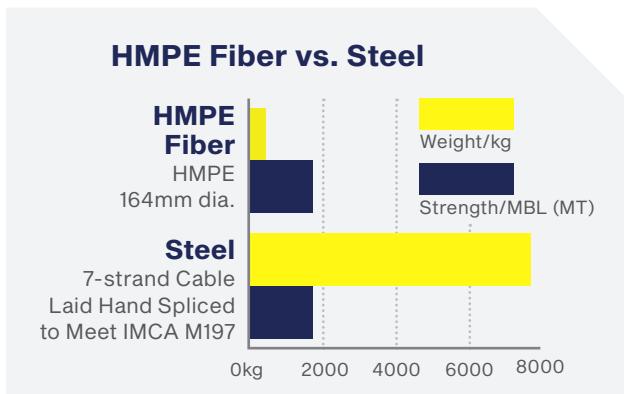

Benefits of HMPE Fiber vs. Steel

- Lighter and easier to handle
- Reduced risk of injury
- Remarkably durable, will not rust or corrode
- No broken/protruding wires
- Saves on transportation, storage, set-up
- Low maintenance
- Not affected by salt or freshwater
- Easy to inspect and splice

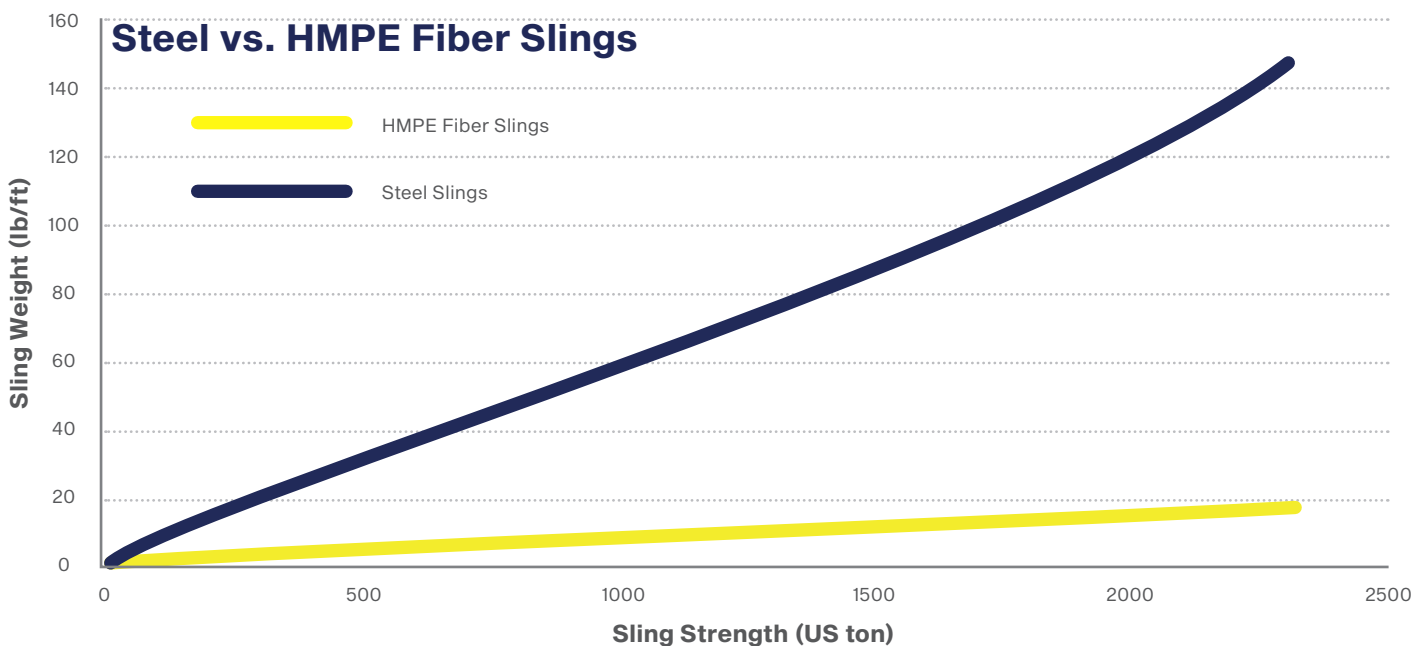

PHYSICAL PROPERTIES OF HMPE

Creep

Creep refers to the irreversible elongation of a rope under constant loading. Ropes experiencing creep often maintain relatively high breaking strengths until they are on the verge of failure, highlighting the importance of monitoring operating conditions that could cause excessive creep. When used within the recommended working load limit (WLL) and temperature range, HMPE exhibits minimal creep elongation during normal operations.

The risk of a rope creeping can be simplified into “The Three Ts”: tension, temperature, and time. Any operating conditions involving high loads, elevated temperatures, or extended durations will increase the likelihood of elongation due to creep.

Abrasion Resistance

HMPE is renowned for its superior abrasion resistance compared to other fibers. This attribute is due to the molecular alignment of the polymer and the fiber’s low coefficient of friction. When braided into a rope, this property allows the fibers to move easily relative to one another, minimizing damage from abrasion.



WARNING



Temperature Resistance

High-Temperature Considerations:

1. Strength Loss Threshold: HMPE ropes begin to irreversibly lose strength at temperatures above approximately 65°C (150°F).
 - Usage Restriction: Do not use HMPE ropes if ambient or contact temperatures exceed this limit.
2. Storage and Exposure Limits:
 - Short-Term Exposure: Avoid storage or exposure to temperatures over 70°C (160°F) for more than two hours.
 - Critical Temperature Limit: Never expose HMPE ropes to temperatures above 130°C (265°F), even briefly.

Low-Temperature Performance:

1. Strength in Cold Environments: HMPE fiber ropes exhibit no loss of strength in cold temperatures and may even gain strength at extremely low temperatures.
2. Ice Removal: Always remove any ice from slings before use to ensure safety and effectiveness.



CHEMICAL EXPOSURE

HMPE fiber is impervious to most common chemicals, but degradation is subject to time of exposure, concentration of chemical, temperature, and overall conditions. Chemically active environments can affect the strength of synthetic fiber rope slings in varying degrees from moderate to total degradation. See general guidance below, but contact KWRS for guidance if the load handling sling will be used in a potentially damaging chemical environment.

Resistance to Chemical Immersion

	6 Mos.	2 Yrs.
Seawater	Safe	Safe
Hydraulic Fluid	Safe	Safe
Kerosene	Safe	Safe
10% Detergent Solution	Safe	Safe
Gasoline	Safe	Safe
Toluene	Safe	Moderate
Glacial Acetic Acid	Safe	Safe
1M Hydrochloric Acid	Safe	Safe
5M Sodium Hydroxide	Safe	Safe
Ammonium Hydroxide (29%)	Safe	Safe
Perchloroethylene	Safe	Safe
Clorox Bleach	Fair	Do Not Use
Hypophosphite Solution (10%)	Safe	No Data
Nitric Acid	Moderate	No Data
Sulfuric Acid	Resistant	No Data
Phosphoric Acid	Moderate	No Data

ROPE SLING CONFIGURATION

Just as important as selecting the right fiber and construction, selecting the correct configuration will further enhance the performance of any sling. There are two primary configurations for fiber rope slings:

Eye and Eye Slings

When spliced into an eye and eye sling, HMPE will essentially act as a size-for-size replacement for a traditional steel wire rope sling in terms of strength. Each end is terminated using a KWRS approved splice which becomes locked in place after proof load testing.

Due to the splice length and free span requirements as shown in the drawing below, eye and eye slings have a minimum length that must be considered. The sling can be made only so short due to the splices. Refer to minimum sling length column in the sling rating charts.

Eye and Eye fabrication with splice-terminated eyes at each end:



- Minimum D:d ratio in the eyes is 1:1
- Minimum eye length must be 6x the bearing surface diameter or pin diameter to maintain the vertex angle below 300
- Rated capacity of eye and eye slings in a vertical pull include splice efficiencies
- When basketing eye and eye slings, the rated capacity will be affected when the basket point D:d ratio is less than 25:1

Endless Grommet Slings

Grommets are manufactured by splicing the ends of a rope together to form a continuous loop. Compared to eye and eye slings, they have increased strength with little to no increase in the chosen rope diameter due to two legs holding the load. Alternatively, the same load can be held with a smaller rope diameter due to the two legs holding the load.

The breaking strength of endless grommet slings is directly affected by the pin diameter on which they are mounted.

Grommet (endless loop):



Grommet (endless loop) with formed eyes at each end:





continued

- Grommet sling rated capacity is directly related to the contact curvature on which it will be used
- Grommet sling ultimate strength is based on applying a configuration factor (CF) to the single leg strength to which the rope is made

PROOF LOADING

Proof-loading is a non-destructive process which subjects the completed sling assembly to a predetermined load, typically 40% of the MBL of the rope.

After fabrication, KWRS fiber rope slings will be subjected to preload or proof-load testing. Physical properties that change while load testing are:

- Diameter will decrease
- Length will increase

During the initial proof load testing, the rope will experience constructional elongation. The purpose of preloading is to remove constructional stretch and stabilize the elongation properties of the sling. During this process the rope will elongate approximately 5–6% and reduce in diameter.

It is at this time that the as-built, fabricated length of the sling is taken (i.e., after proof load testing).

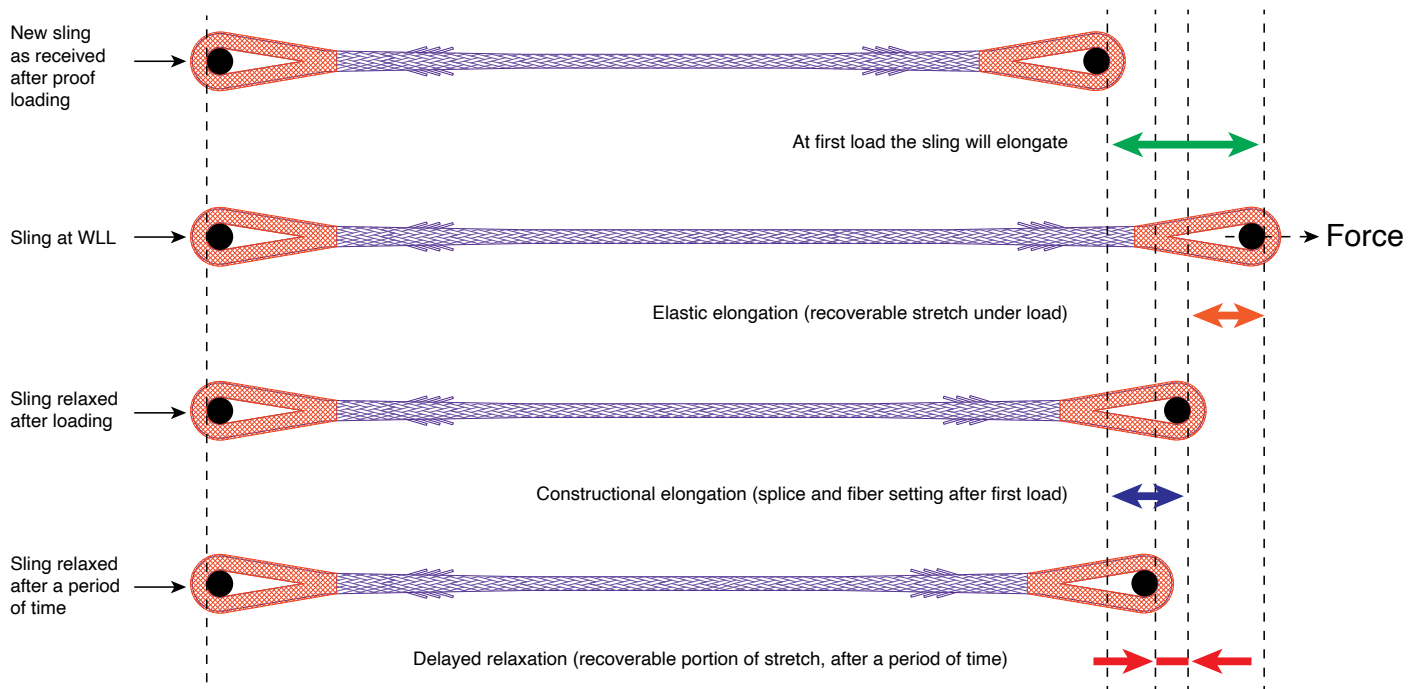

REMOVAL CRITERIA

There are no precise rules to determine the exact time for the removal of the rope since many variable factors are involved. Inspection methods and retirement criteria specific to a given rope design shall be provided by the rope manufacturer. Once a rope reaches any one of the removal criteria, it shall be replaced. Specific inspection attributes and removal criteria include the following:

- Damage that is estimated to have reduced the effective diameter of the rope by more than 10%, as compared to an unaffected section of the rope
- Cuts, gouges, areas of extensive yarn material breakage along the length, and abraded areas on the rope
- Uniform yarn material breakage along the major part of the length of the rope, such that the entire rope appears covered with fuzz or whiskers
- Inside the rope, yarn material breakage, fused or melted yarn material involving damage estimated at more than 10% of the diameter of the rope or affecting more than 10% of strand diameters in half of the strands in a lay length. This may be observable by prying or twisting to open the strands in some rope constructions, as recommended by the rope manufacturer
- Discoloration, brittle yarns, and hard or stiff areas that may indicate chemical damage, ultraviolet damage, or heat damage
- Dirt and grit in the interior of the rope structure that is causing damage to rope yarns.
- Kinks or distortion in the rope structure, particularly if caused by forcibly pulling on the loops (known as hockles)
- Melted, hard, or charred areas that affect more than 10% of the diameter of the rope or affect more than 10% of strand diameters in half of the strands in a lay length
- Any apparent damage from a heat source, including, but not limited to, welding, power line strikes, or lightning
- Poor condition of thimbles or other components manifested by corrosion, cracks, distortion, sharp edges, or localized wear
- End terminations removal criteria include severely corroded, cracked, bent, worn, grossly damaged, or improperly installed end terminations
- For jacketed rope, completely broken jackets that no longer protect the load-bearing fiber
- Other conditions, including visible damage, that cause doubt as to the continued use of the rope



SLING PROTECTION

If additional protection from the elements, cutting, abrasion, or mud ingress is needed, KWRS offers several wear protection options. Fiber rope slings can be completely covered in protection, or simply protected in critical contact areas; e.g. the basket lifting point, or the eyes. Options include:

HMPE Braided Chafe



Combining the lightweight, abrasion resistant and non-water absorbing properties

of HMPE fiber, Braided Chafe protection is a tightly braided tubular structure which can be freefloating or fitted onto the sling to offer the highest protection from cuts and abrasion that KWRS offers.

HMPE Narrow Woven



Combining the lightweight, abrasion resistant and non-water absorbing properties of

HMPE fiber, Narrow Woven protection is a lightweight woven fabric structure which is easy to install and retrofit on existing slings, providing protection from cuts and abrasion.

Sidewinder



A cost-effective woven fabric material, Sidewinder is the most commonly used protection for abrasion. This protection is available as a permanent installation,

or in a removable / replaceable form with a hook-and-loop closure.





Kennedy

Wire Rope & Sling Company

CORPUS CHRISTI

302 Flato Road
Corpus Christi, TX 78405
Phone: (800) 289-1445
Fax: 361-289-7555

SAN ANTONIO

4202 Dividend Dr
San Antonio, TX 78219
Phone: (833) 460-3095
Fax: 210-527-9701

HOUSTON

5600 Surrey Square
Houston, TX 77017
Phone: (800) 392-5510
Fax: 713-673-2901





Certificate No. 7340



AFFILIATES



 For more information, visit us at kwrs.com

 @kennedywrs

 @kennedywireropeslingco

 Kennedy Wire Rope & Sling Co.